

TM 5-4610-233-13&P

TECHNICAL MANUAL

**OPERATOR, UNIT, AND DIRECT SUPPORT
MAINTENANCE MANUAL
(Including Repair Parts and
Special Tools List)**

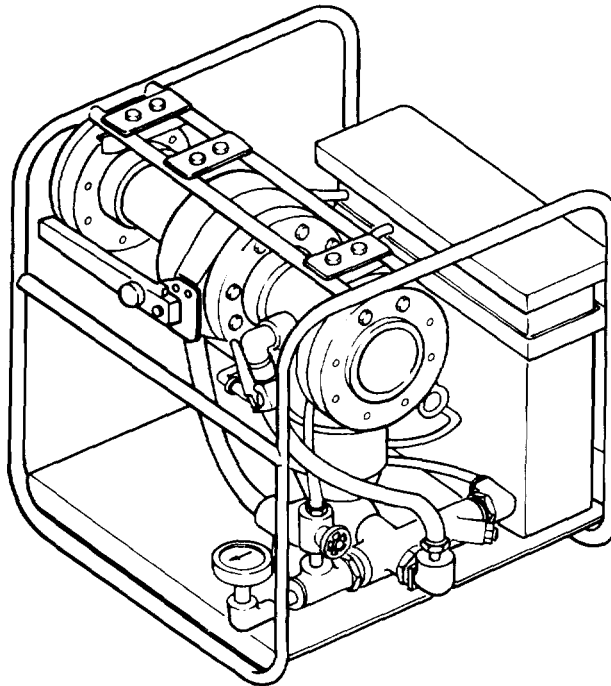

**WATER PURIFICATION
HYPOCHLORINATION UNIT, FRAME-
MOUNTED, AUTOMATICALLY
CONTROLLED, 350 GPM,
MODEL 1955-3
(NSN 4610-01-250-3724)**

Approved for public release; distribution is unlimited.

**HEADQUARTERS, DEPARTMENT OF THE ARMY
12 APRIL 1990**

CHANGE
NO. 2

HEADQUARTERS
DEPARTMENT OF THE ARMY
WASHINGTON, D.C. 7 June 1996

Operator, Unit and Direct Support
Maintenance Manual
(Including Repair Parts and Special Tools List)

WATER PURIFICATION HYPOCHLORINATION UNIT,
FRAME-MOUNTED, AUTOMATICALLY CONTROLLED, 350 GPM,
MODEL 1955-3
(NSN 4610-01-250-3724)

DISTRIBUTION STATEMENT A: Approved for public release; distribution is unlimited.

TM 5-4610-233-13&P, 12 April 1960, is changed as follows:

1. Remove and insert pages as indicated below. New or changed text material is indicated by a vertical bar in the margin. An illustration change is indicated by a miniature pointing hand.

Remove pages

i and ii
1-1 and 1-2
4-11 through 4-20
4-31 through 4-44
B-5 and B-6
E-1 and E-2

Insert pages

i and ii
1-1 and 1-2
4-11 through 4-20
4-31 through 4-44
B-5 and B-6
E-1 and E-2

2. Retain this sheet in front of manual for reference purposes.

By Order of the Secretary of the Army:

Official:



Handwritten signature of Joel B. Hudson in black ink.

JOEL B. HUDSON

*Administrative Assistant to the
Secretary of the Army*

01886

DENNIS J. REIMER
*General, United States Army
Chief of Staff*

DISTRIBUTION:

To be distributed in accordance with DA Form 12-25-E, block no. 5505, requirements for
TM 5-4610-233-13&P.

CHANGE
NO. 1

HEADQUARTERS
DEPARTMENT OF THE ARMY
WASHINGTON, D.C., 31 March 1993

OPERATOR, UNIT, AND DIRECT SUPPORT
MAINTENANCE MANUAL
(INCLUDING REPAIR PARTS AND SPECIAL TOOLS LIST)

WATER PURIFICATION
HYPOCHLORINATION UNIT, FRAME-MOUNTED
AUTOMATICALLY CONTROLLED, 350 GPM,
MODEL 1955-3 (NSN4610-01-250-3724)

DISTRIBUTION STATEMENT A: Approved for public release; distribution is unlimited.

TM 5-4610-233-13&P, 12 April 1990, is changed as follows:

1. Remove and insert pages as indicated below. New or changed text material is indicated by a vertical bar in the margin. An illustration change is indicated by a miniature pointing hand.

Remove pages	Insert pages
1-1 and 1-2	1-1 and 1-2
1-5/(1-6 blank)	1-5/(1-6 blank)

2. Retain this sheet in front of manual for reference purposes.

By Order of the Secretary of the Army:

GORDON R. SULLIVAN
General, United States Army
Chief of Staff

Official:

MILTON H. HAMILTON
Administrative Assistant to the
Secretary of the Army
03813

DISTRIBUTION:

To be distributed in accordance with DA Form 12-25-E, block no. 5505, requirements for TM 5-4610-233-13&P.

W A R N I N G
HEAVY EQUIPMENT HAZARD

Lifting or moving heavy equipment incorrectly can cause serious injury. Do not try to lift or move more than 50 pounds (22.7 kg) by yourself, Get an assistant. Bend your legs while lifting. Don't support heavy weight with your back.

WARNING

HIGH PRESSURE HAZARD

The water purification hypochlorination unit contains water under high pressure during and after operation. If this pressure is not relieved before working on the unit, serious injury may occur. Be sure to relieve pressure before beginning any disassembly.

WARNING

TOXIC CHEMICAL HAZARD

Hypochlorite solution is toxic to skin and eyes. Avoid repeated or prolonged contact. Wear skin and eye protection.

For Artificial Respiration, refer to FM 21-11.

TECHNICAL MANUAL
NO. 5-4610-233-13&P

HEADQUARTERS
DEPARTMENT OF THE ARMY
WASHINGTON, D.C., 12 April 1990

Operator, Unit, and Direct Support
Maintenance Manual
(Including Repair Parts and Special Tools List)

**WATER PURIFICATION HYPOCHLORINATION UNIT,
FRAME-MOUNTED, AUTOMATICALLY CONTROLLED, 350 GPM,
MODEL 1955-3
(NSN 4610-01-250-3724)**

(Current as of 1 May 1989)

REPORTING ERRORS AND RECOMMENDING IMPROVEMENTS

You can help improve this manual. If you find any mistakes, or if you know of a way to improve these procedures, please let us know. Mail your letter, DA Form 2028 (Recommended Changes to Publications and Blank Forms) or DA Form 2028-2 located in the back of this manual directly to: Commander, US Army Aviation and Troop Command, ATTN: AMSAT-I-MP, 4300 Goodfellow Blvd., St. Louis, MO 63120-1798. You may also submit your recommended changes by E-mail directly to <mpmt%avma28@st-louis-emh7.army.mil>. A reply will be furnished directly to you. Instructions for sending an electronic 2028 maybe found at the back of this manual immediately preceding the hard copy 2028.

DISTRIBUTION STATEMENT A: Approved for public release; distribution is unlimited.

TABLE OF CONTENTS

	PAGE
HOW TO USE THIS MANUAL	lii
CHAPTER 1 INTRODUCTION	1-1
Section I General Information	1-1
Section II Equipment Description	1-2
Section III Principles of Operation	1-4
CHAPTER 2 OPERATING INSTRUCTIONS	2-1
Section I Description and Use of Operator's Controls and Indicators	2-1
Section II Operator Preventative Maintenance Checks and services (PMCS)	2-2
Section III Operation Under Usual Conditions	2-5
Section IV Operation Under Unusal Conditions	2-11
CHAPTER 3 OPERATOR MAINTENANCE	3-1
Section I Lubrication Instructions	3-1
Section II Operator Troubleshooting	3-1
Section III Operator Maintenance Procedures	3-7

TABLE OF CONTENTS- Cont

	Page	Illus/ Figure	
CHAPTER 4	UNIT MAINTENANCE	4-1	
Section I	Repair Parts; Special Tools; Test, Measurement, end Diagnostic Equipment (TMDE); and Support Equipment	4-1	
Section II	Service Upon Receipt	4-2	
Section III	Unit Preventive Maintenance Checks and Services (PMCS)	4-2	
Section IV	Unit Troubleshooting	4-3	
Section V	Unit Maintenance Procedures	4-7	
Section VI	Preparation For Storage or Shipment..	4-44	
CHAPTER 5	DIRECT SUPPORT MAINTENANCE	5-1	
APPENDIX A	REFERENCES	A-1	
APPENDIX B	MAINTENANCE ALLOCATION CHART	B-1	
APPENDIX C	COMPONENTS OF END ITEM AND BASIC ISSUE ITEMS LIST	C-1	
APPENDIX D	ADDITIONAL AUTHORIZATION LIST (AAL)	D-1	
APPENDIX E	EXPENDABLE/DURABLE SUPPLIES AND MATERIALS LIST	E-1	
APPENDIX F	OPERATOR, UNIT, AND DIRECT SUPPORT MAINTENANCE REPAIR PARTS AND SPECIAL LIST	F-1	
Section I	Introduction	F-1	
Section II	Repair Parts List	F-9	
Group 00	Frame-Mounted Water Purification Hypochlorination Unit	F-10	F-1
Group 01	Solution Feed Pump	F-18	F-2
Group 02	Flow Controller with Meter Adapter Parts	F-20	F-3
Group 03	4-Inch Manifold Assembly	F-22	F-4
Group 04	Manifold Assembly with Pressure Gage, Globe Valve, and Fill Hose	F-24	F-5
Group 05	Frame	F-26	F-6
Group 06	Chlorine Comparator Kit	F-28	F-7
Group 07	Bulk	F-30	
Section III	Special Tools List (Not Applicable)		
Section IV	Cross-Reference Indexes.	F-33	
	National Stock Number Index	F-33	
	Part Number Index	F-34	
	Figurer and Item Number Index	F-37	
	SUBJECT INDEX	Index-1	

HOW TO USE THIS MANUAL

Spend a few minutes looking through this manual. It has a new look that is very different from the manuals you've been using. You'll find the new look is a lot easier to use, and you can find what you're looking for a lot faster.

Each chapter begins with an index that lists each paragraph (in alphabetical order) in the chapter and gives page numbers. Or you can look for the information you want in the alphabetical subject index at the back of the manual.

We got rid of as many words as we could and put in lots of illustrations to show just about everything you'll be doing to maintain your equipment.

The text is keyed to the illustrations with callout numbers (sometimes words). The callout numbers are in parentheses in the text.

So HOW DO YOU USE THIS MANUAL?

Like This:

1. Suppose the operator notified unit maintenance that the chlorine residual test indicated no chlorine in treated water and you want to troubleshoot the hypochlorination unit.
2. Look at the Table of Contents in the front of the manual and find "UNIT MAINTENANCE" and it gives you page 4-1.

TM 5-4610-233-13&P		TABLE OF CONTENTS - Cont.	
		Page	Ilus/ Figure
CHAPTER 4	UNIT MAINTENANCE	4-1	
Section I	Repair Parts, Special Tools, Test, Measurement, and Diagnostic Equipment (TMDE), and Support Equipment	4-1	
Section II	Service Upon Receipt	4-2	
Section III	Unit Preventive Maintenance Checks and Services (PMCS)	4-2	
Section IV	Unit Troubleshooting	4-3	
Section V	Unit Maintenance Procedures	4-7	
Section VI	Preparation For Storage or Shipment	4-44	
CHAPTER 5	DIRECT SUPPORT MAINTENANCE	5-1	
APPENDIX A	REFERENCES	A-1	
APPENDIX B	MAINTENANCE ALLOCATION CHART	B-1	
APPENDIX C	COMPONENTS OF END ITEM AND BASIC ISSUE ITEMS LIST	C-1	
APPENDIX D	ADDITIONAL AUTHORIZATION LIST (AAL)	D-1	
APPENDIX E	EXPENDABLE/DURABLE SUPPLIES AND MATERIALS LIST	E-1	
APPENDIX F	OPERATOR, UNIT, AND DIRECT SUPPORT MAINTENANCE REPAIR PARTS AND SPECIAL TOOLS LIST	F-1	
Section I	Introduction	F-1	
Section II	Repair Parts List	F-9	
Group 00	Frame Mounted Water Purification Hypochlorination Unit	F- F-1	
Group 01	Solution Feed Pump	F- F-2	
Group 02	Flow Controller with Meter Adapter Parts	F- F-3	
Group 03	4 Inch Manifold Assembly	F- F-4	
Group 04	Manifold Assembly with Pressure Gage Globe Valve, and Fill Hose	F- F-5	
Group 05	Frame	F- F-6	
Section III	Special Tools List (Not Applicable)	F-	
Section IV	Cross Reference Index	F-	
	National Stock Number Index	F-	
	Part Number Index	F-	
	Figure and Item Number Index	F-	
	SUBJECT INDEX	Index-1	

TM 5-4610-233-13&P

CHAPTER 4
UNIT MAINTENANCE

	para	Page
Administrative Storage Requirements	4-35	4-44
Common Tools and Equipment	4-1	4-1
Explanation of Columns	4-6	4-2
General	4-5	4-2
Preservation, Packaging, Marking, and Shipping Requirements	4-7	4-3
Repair Check Valve	4-24	4-28
Repair Drain Hose Assembly	4-18	4-20
Repair Inlet Hose Assembly	4-14	4-18
Repair Manifold Assembly	4-30	4-38
Repair Outlet Hose Assembly	4-16	4-18
Repair Parts	4-3	4-2
Repair Solution Feed Pump	4-20	4-22
Repair 4 inch Manifold Assembly	4-28	4-38
Replace Aeration Valve	4-22	4-25
Replace Check Valve	4-23	4-27
Replace Drain Hose Assembly	4-17	4-19
Replace Flow Controller	4-26	4-31
Replace Foot Valve	4-21	4-23
Replace Hypochlorination Unit Frame	4-33	4-43
Replace Inlet and Outlet Hoses	4-11	4-10
Replace Inlet Hose Assembly	4-13	4-15
Replace Manifold Assembly	4-29	4-38
Replace Outlet Hose Assembly	4-15	4-17
Replace Pressure Gage	4-31	4-40
Replace Reservoir Tank Assembly	4-10	4-8
Replace Shutoff Cock	4-12	4-12
Replace Solution Feed Pump	4-19	4-21
Replace Solution Feed Pump Diaphragm	4-25	4-29
Replace Tool Box	4-8	4-7
Replace 1/4 inch Globe Valve	4-32	4-41
Replace 4 inch Manifold Assembly	4-27	4-34
Service Upon Receipt of Material	4-4	4-2
Special Tools, TMDE, and Support Equipment	4-2	4-2
Troubleshooting Table	4-8	4-3

Section I. REPAIR PARTS; SPECIAL TOOLS; TEST, MEASUREMENT, AND DIAGNOSTIC EQUIPMENT (TMDE); AND SUPPORT EQUIPMENT

4-1. COMMON TOOLS AND EQUIPMENT. For authorized common tools and equipment, refer to the Modified Table of Organization and Equipment (MTOE) applicable to your unit.

4-1

- On page 4-1, you'll find CHAPTER 4, UNIT MAINTENANCE. The chapter index will give you page 4-3 for the troubleshooting table.

TM 5-4610-233-13&P	
Table 4-2. Unit Troubleshooting - Cont	
Malfunction	Test or Inspection Corrective action
1. SOLUTION FEED PUMP AIRLOCKED AT STARTUP - continued	<p>Step 2. Check that solution feed pump diaphragm is good. Replace diaphragm. Refer to paragraph 4-25.</p> <p>Step 3. Check that solution feed pump is good. Replace solution feed pump. Refer to paragraph 4-19.</p>
2. CHLORINE RESIDUAL TEST INDICATES NO CHLORINE IN TREATED WATER	<p style="text-align: center;">WARNING</p> <p>Hypochlorite solution is toxic to skin and eyes. Wear skin and eye protection to prevent personal injury.</p> <p>Step 1. Check that solution feed pump is discharging hypochlorite solution. Close inlet shutoff cock, outlet shutoff cock, and hypochlorite solution shutoff cock. Disconnect solution feed pump discharge hose with injection nozzle from hypochlorite solution shutoff cock. Hold solution feed pump discharge hose aimed toward open reservoir tank assembly. Open inlet shutoff cock. Slowly open outlet shutoff cock. Observe that hypochlorite solution is discharged into the reservoir tank assembly. Close outlet shutoff cock and inlet shutoff cock. If hypochlorite solution is discharged, replace antisiphon valve. Refer to paragraph 4-22. If hypochlorite solution is not discharged, connect solution feed pump discharge hose to hypochlorite solution shutoff cock and go to step 2.</p> <p>Step 2. Check that operating water is transferred to the solution feed pump. Close inlet shutoff cock, outlet shutoff cock, and hypochlorite solution shutoff cock.</p>

4. Look through the troubleshooting table and find the malfunction CHLORINE RESIDUAL TEST INDICATES NO CHLORINE IN TREATED WATER.
5. As you do the tests and corrective actions in the order listed, you will get to "If hypochlorite solution is discharged, replace antisiphon valve. Refer to paragraph 4-22."
6. Go back to the chapter index on page 4-1 and look for "Replace Antisiphon Valve" and it gives you page 4-25. (Remember, the chapter index is in alphabetical order.)

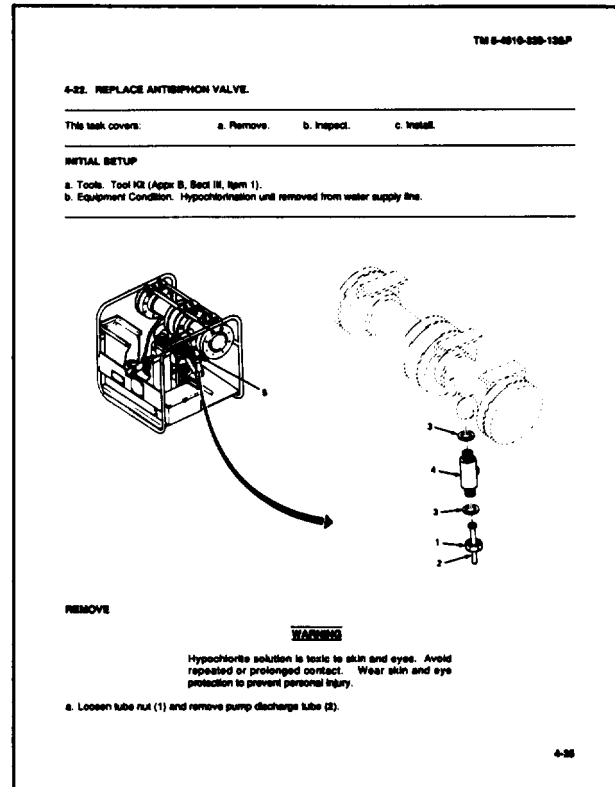

7. Turn to page 4-25 and look at the procedure, The procedure is divided into modules with one or more steps and a picture to show you whereto look and what to look at.
8. Notice the numbered arrows. These are the callout numbers. As you read each step, we tell you whereto look by including the callout number (in parentheses) after the name of each thing we call out.
9. Do the procedure, then check to see if you have corrected the malfunction.

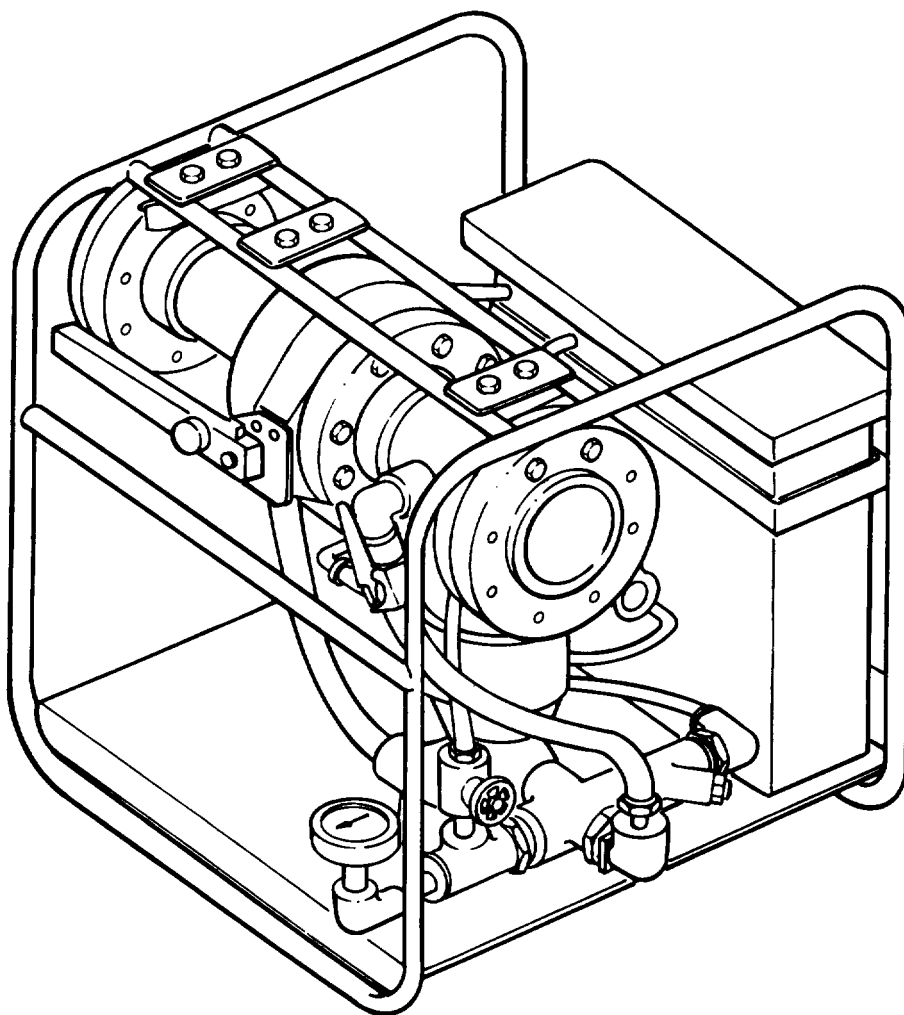

Figure 1-1. Water Purification Hypochlorination Unit, Model 1955-3

CHAPTER 1

INTRODUCTION

	Para	Page
Destruction of Army Materiel To Prevent Enemy Use	1-5	1-1
Equipment Characteristic, Capabilities, and Features	1-9	1-2
Equipment Data.....	1-11	1-3
Location and Description of Major Components.....	1-10	1-2
Maintenance Forms, Records, and Reports	1-2	1-1
Preparation for Storage or Shipment.....	1-8	1-1
Quality Assurance/Quality Control (QA/QC)	1-7	1-2
Reporting Equipment Improvement Recommendations (EIR).....	1-3	1-1
Safety, Care, and Handling	1-8	1-2
Schematic Description.....	1-12	1-4
Scope	1-1	1-1
Warranty Information	1-4	1-1

Section I. GENERAL INFORMATION

1-1. SCOPE. This manual contains operation and maintenance instructions for Water Purification Hypochlorination Unit Model 1955-3 (figure 1-1), hereinafter called hypochlorination unit. This manual includes procedures for operation, cleaning, inspection, testing, servicing, disassembly, and assembly of the equipment for operator through direct support maintenance as authorized by the Maintenance Allocation Chart (MAC).

1-2. MAINTENANCE FORMS, RECORDS, AND REPORTS. Department of the Army forms and procedures used for equipment maintenance will be those prescribed by DA Pam 738-750, The Army Maintenance Management System (TAMMS).

1-3. REPORTING EQUIPMENT IMPROVEMENT RECOMMENDATIONS (EIR'S). If your hypochlorination unit needs improvement, let us know. Send us an EIR. You, the user, are the only one who can tell us what you don't like about your equipment. Let us know why you don't like the design or performance. Put it on a SF 368 (Quality Deficiency Report). Mail it to us at: Commander, U.S. Army Aviation and Troop Command, ATTN: AMSAT-I-MDO, 4300 Goodfellow Blvd., St. Louis, MO 63120-1798. We will send you a reply.

1-4. WARRANTY INFORMATION. The hypochlorination unit is warranted by Waltron Ltd. for 18 months from date of delivery. Report all defects in material or workmanship to your supervisor who will take appropriate action.

1-5. DESTRUCTION OF ARMY MATERIEL TO PREVENT ENEMY USE. Destruction of Army materiel to prevent enemy use is described in TM 750-244-3.

1-6. PREPARATION FOR STORAGE OR SHIPMENT. Preparation instructions for storage or shipment are found in Chapter 4, Section VI.

1-7. QUALITY ASSURANCE/QUALITY CONTROL (QA/QC). Maintenance standards for the hypochlorination unit are given in the preventive maintenance sections and the maintenance chapters of this manual. By performing PMCS and the maintenance procedures, quality control of the equipment will be maintained.

1-8. SAFETY, CARE, AND HANDLING. Observe all WARNINGS, CAUTIONS, and NOTES in this manual. This equipment can be dangerous if these instructions are not followed.

Section II. EQUIPMENT DESCRIPTION AND DATA

1-9. EQUIPMENT CHARACTERISTICS, CAPABILITIES, AND FEATURES.

Characteristic

Placed in a water supply line, will chlorinate water flowing through the line unattended for a minimum of 2 hours.

Capabilities and Features

Feed hypochlorite solution in direct proportion to waterflow rate.

Portable frame-mounted.

Chlorinates waterflow rate from 2 to 350 gallons per minute.

Uses water pressure as power source.

1-10. LOCATION AND DESCRIPTION OF MAJOR COMPONENTS. See figure 1-2.

a. *Four-Inch Manifold (1)*. A 4-inch diameter pipe for connection to a water supply line. The manifold provides lateral outlets to power the solution feed pump and permit hypochlorite solution injection to the waterflow.

b. *Range Adjusting Valve (2)*. Mounted in the manifold and used to bypass enough waterflow through the water meter to operate the solution feed pump.

c. *Flow Controller (3)*. A mechanical flowmeter modified with a gear box and a control pilot valve to operate the solution feed pump.

d. *Solution Feed Pump (4)*. A hydraulically operated positive displacement proportioning pump. ■

e. *Reservoir Tank (5)*. A 6-gallon plastic tank holding the hypochlorite and water solution.

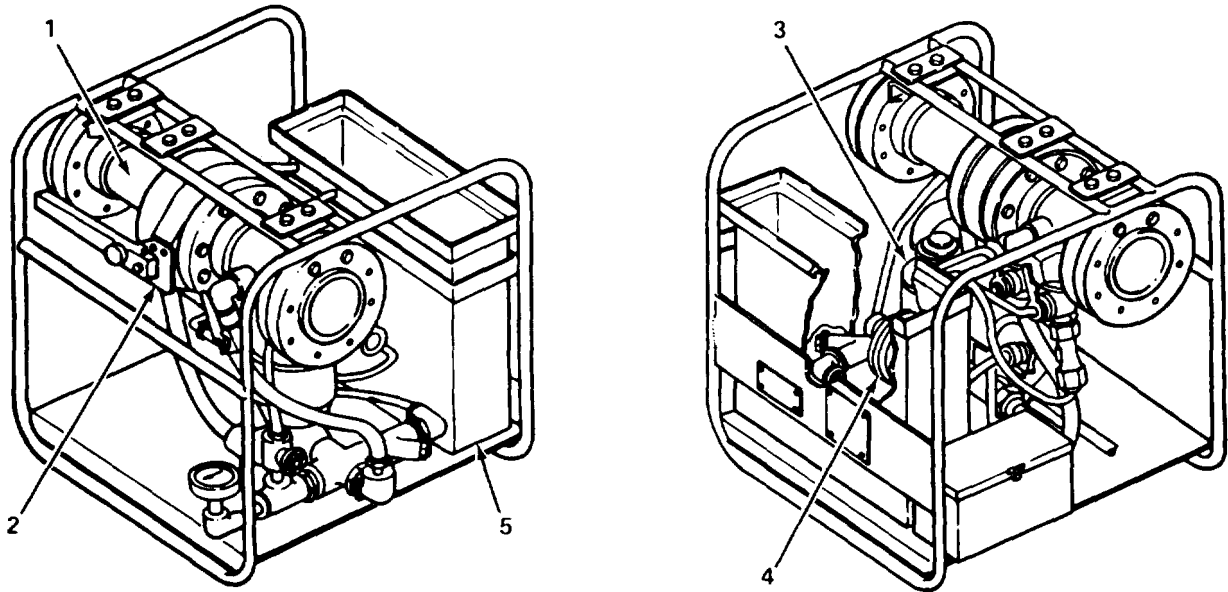

Figure 1-2. Location of Major Components

1.11 EQUIPMENT DATA.

Hypochlorination Unit

Weight (net)	241 lb (109.3 kg)
Length	33 in. (83.8 cm)
Width	26 in. (66.04 cm)
Height	28 in. (71.12 cm)

Reservoir Tank

Capacity	6 gal ±1 pt (22.7 l ±0.5 l)
Length	18 in. (45.72 cm)
Width	4 in. (10.16 cm)
Height	18 in. (45.72 cm)

Section III. PRINCIPLES OF OPERATION

1-12. SCHEMATIC DESCRIPTION. The hypochlorination unit (see figure 1-3) provides for the addition of hypochlorite solution to unchlorinated water using hydraulic pressure from the untreated water.

a. The range adjusting valve (1) diverts operating water from the 4-inch manifold (2) through the inlet shutoff cock (3).

b. The operating water flows through the inlet shutoff cock to the flow controller (4). The operating water flowing through the flow controller returns to the water supply through the outlet shutoff cock (5).

c. The flow controller converts the circular motion imparted by the operating water to a reciprocating action for operation of the control pilot valve (6).

d. In charge position, the control pilot valve passes operating water to the solution feed pump (7). In discharge position, the pilot valve exhaust operating water passed to the solution feed pump through the pilot valve drain hose (8).

e. The operating water causes the solution feed pump to perform a discharge stroke emptying the liquid head assembly (9). When the pilot valve changes to discharge position, the solution feed pump returns to the ready position forcing the operating water to drain and producing a suction like stroke.

f. The discharge stroke of the solution feed pump expels the contents of the operating chamber of the liquid head assembly (9) out the injection nozzle (10) into the manifold. The suction-like stroke causes the operating chamber to fill with hypochlorite solution from the reservoir tank (11).

g. The pressure gage (12) provides constant monitoring of the water pressure.

h. The 1/4-inch globe valve and fill hose (13) permit replenishment of water in the reservoir tank with unchlorinated operating water.

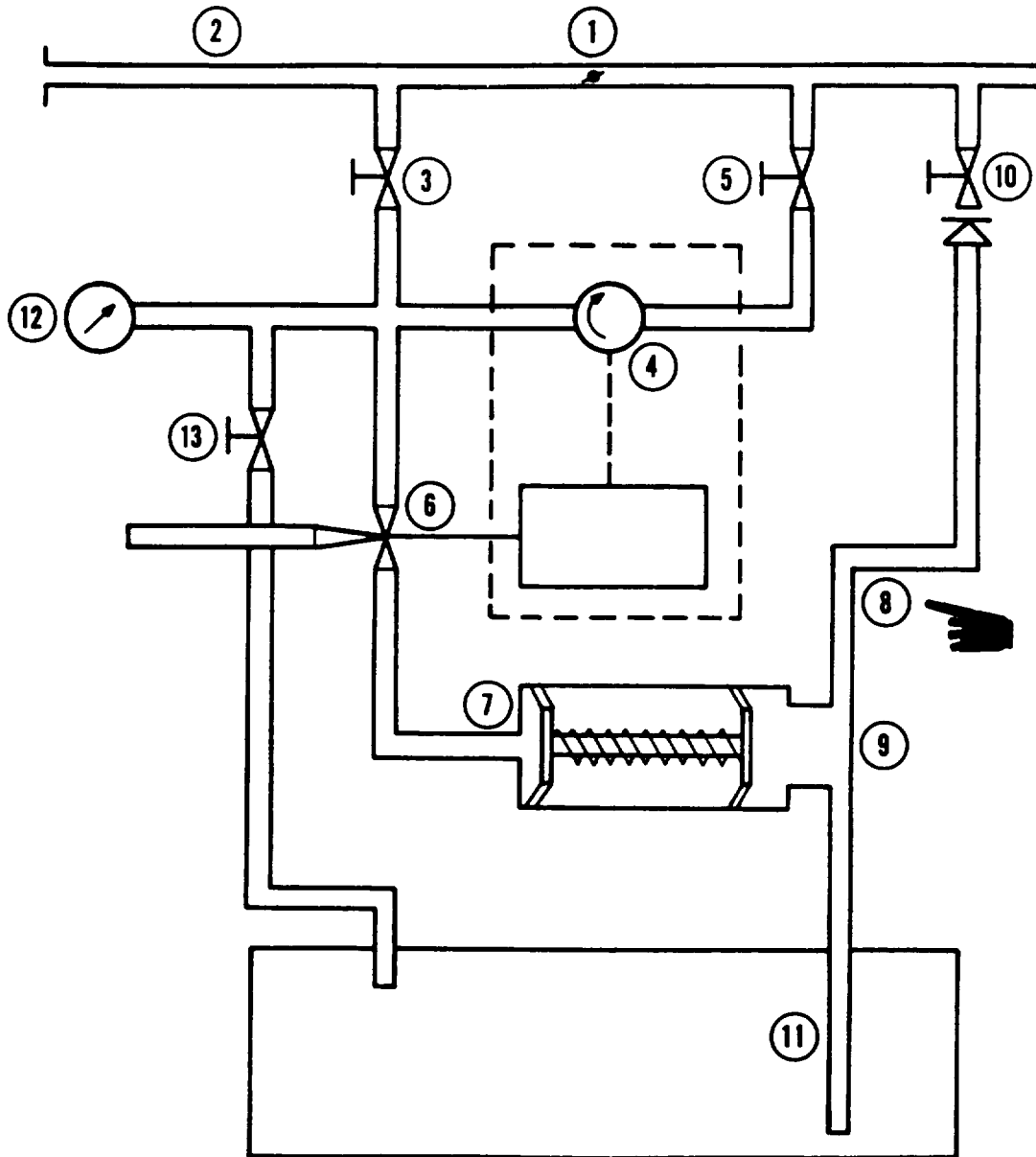

Figure 1-3. Hypochlorination Unit Schematic Diagram

CHAPTER 2

OPERATING INSTRUCTIONS

	Para	Page
Controls and Indicators	2-1	2-1
General	2-2	2-2
Initial Adjustments	2-5	2-6
Operating Instructions on Decals and Instruction Plates	2-8	2-10
Operating Procedure	2-6	2-6
Operation in Unusual Weather	2-9	2-11
PMCS Procedures.....	2-3	2-3
Preparation for Movement.....	2-7	2-9
Preparation for Use	2-4	2-5

Section I. DESCRIPTION AND USE OF OPERATOR'S CONTROLS AND INDICATORS

2-1. CONTROLS AND INDICATORS. Figure 2-1 shows the location of controls and indicators used to operate the hypochlorination unit. Table 2-1 lists the controls and indicators with descriptions.

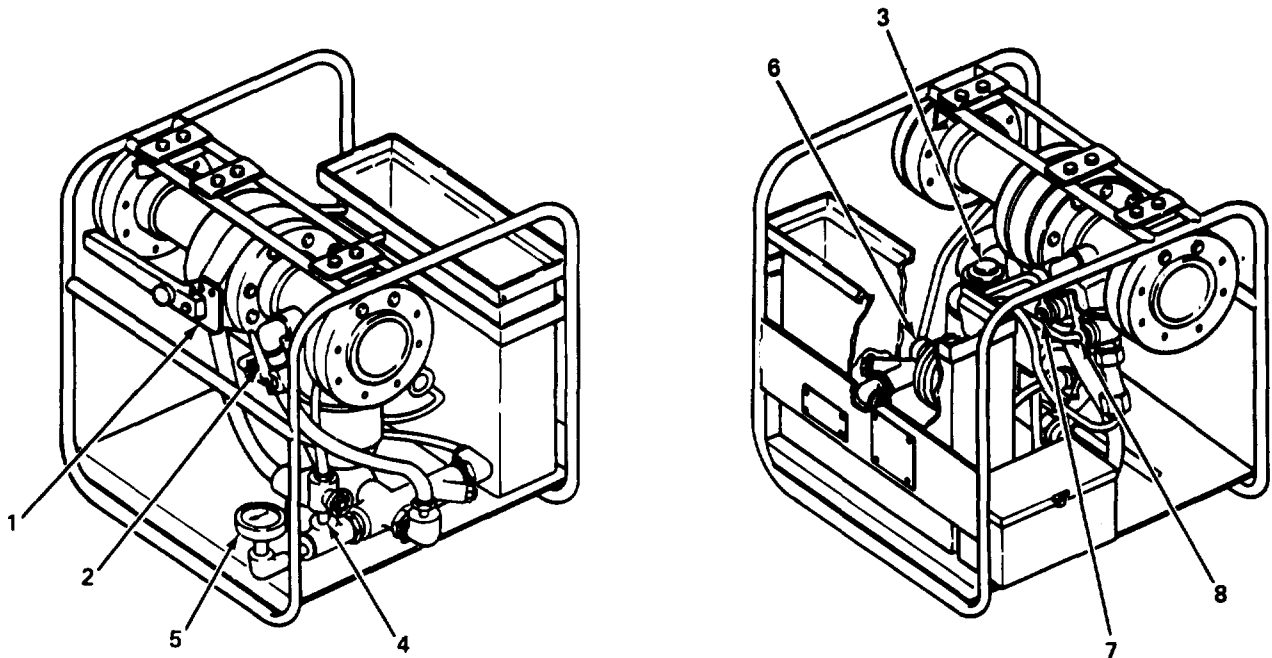

Figure 2-1. Controls and Indicators

Table 2-1. Operator's Controls and Indicators

Key	Control or indicator	Description
1	Range adjustment valve	Used to set waterflow required to operate hypochlorination unit.
2	Inlet shutoff cock	Used to start/stop operating waterflow to hypochlorination unit.
3	Flow controller	Automatically controls flow of operating water in hypochlorination unit.
4	1/4-inch globe valve	Used to refill reservoir tank with water.
5	Pressure gage	Used to monitor water pressure in hypochlorination unit.
6	Solution feed pump stroke adjusting knob	Micrometer adjustable, used to limit amount of hypochlorite solution injected into water supply.
7	Outlet shutoff cock	Used to start/stop operating waterflow to manifold.
8	Hypochlorite solution shutoff cock	Used to close manifold to flow of hypochlorite solution.

**Section II. OPERATOR PREVENTIVE MAINTENANCE
CHECKS AND SERVICES (PMCS)**

2-2. GENERAL. Do the checks and services at the intervals shown, using the following as a guide:

- a. Do your before (B) preventive maintenance just before you operate your equipment. Pay attention to warnings and cautions.
- b. Do your (D) preventive maintenance while the equipment is in operation.
- c. Do your after (A) preventive maintenance right after operating the equipment. Pay attention to warnings and cautions.
- d. Do your weekly (W) preventive maintenance once a week.
- e. Always do your preventive maintenance in the same order.

2-3. PMCS PROCEDURES.

a. Preventive Maintenance. Operator's preventive maintenance checks and services (PMCS) is the required daily and weekly inspection and care of your equipment necessary to keep it in good operating condition.

b. Routine Checks. Routine checks like equipment inventory, cleaning, dusting, washing, checking for frayed cables, stowing items not in use, and checking for loose nuts and bolts are not listed as PMCS checks. They are things that you should do any time you see they must be done.

c. Explanation of Columns. Following is an explanation of the columns of table 2-2.

- (1) Item no. This column shows the sequence of doing the checks and services.
- (2) Interval. These columns tell you when to do a procedure. Each column that applies will contain a dot (•). Some procedures will have dots in more than one column.
- (3) Item to be inspected. This column contains the name of the item to be inspected.
- (4) Procedures. This column tells how to perform the required checks and services on it. Carefully follow these instructions and perform them in the order listed.
- (5) Equipment is not ready/available if:. This column tells you:
 - Why your equipment cannot be used.
 - Why there is a problem with any item that was inspected.
 - What the problem is with the procedure.

Table 2-2. Operator Preventive Maintenance Checks and Services

NOTE: Within designated interval, these checks are to be performed in the order listed.

B - Before
D - During

A - After
W - Weekly

Item no.	Interval				Item to be inspected	Procedures Check for and have repaired or adjusted as necessary	Equipment is not ready/available if:
	B	D	A	W			
1				•	Tool box	Inspect tool box hinge and latch for damage	
2				•	Reservoir tank	Fill with water and inspect for leaks.	
3	•	•		•	Hose assemblies	Inspect for cracks, splits, and breaks.	Hoses are damaged.
4	•	•			Shutoff cocks	Inspect for cracks, leaks, and ease of operation.	Shutoff cock is cracked or leaking.
5		•			Solution feed pump	Visually inspect primed pump for flow.	Fluid not flowing.
6	•				Foot valve assembly	Inspect for damaged or clogged strainer.	If foot valve assembly is inoperable.
7		•			Antisiphon valve	Inspect for damage.	If antisiphon valve is inoperable.
8		•			Check valves	Check for operation.	If check valves are inoperable
9		•			Flow controller	Check for operation and rotation of indicating dials.	If flow controller is damaged.

Table 2-2. Operator Preventive Maintenance Checks and Servloes - Cont

Item no.	Interval				Item to be Inspected	Procedures Check for and have repaired or adjusted as necessary	Equipment is not ready/available if:
	B	D	A	W			
10	●	●			Manifolds	Inspect for cracks and leaks.	Manifold is cracked or leaking.
11	●	●		●	Pressure gage	Inspect for damage, leaks, and operations.	Pressure gage does not operate or leaks.
12		●			1/4-inch globe valve	Inspect for damage, leaks, and operations.	If valve is damaged.
13		●			Drain cock assembly	Inspect for damage, leaks, and operations.	If drain cock assembly is damaged.
14	●				Frame	Inspect for cracks and broken welds.	
15		●		●	Chlorine color comparator	Inspect for broken cells.	Unable to obtain accurate indications.

Section III. OPERATION UNDER USUAL CONDITIONS

2-4. PREPARATION FOR USE. Refer to figure 2-2 and perform the following steps to prepare the hypochlorination unit for use.

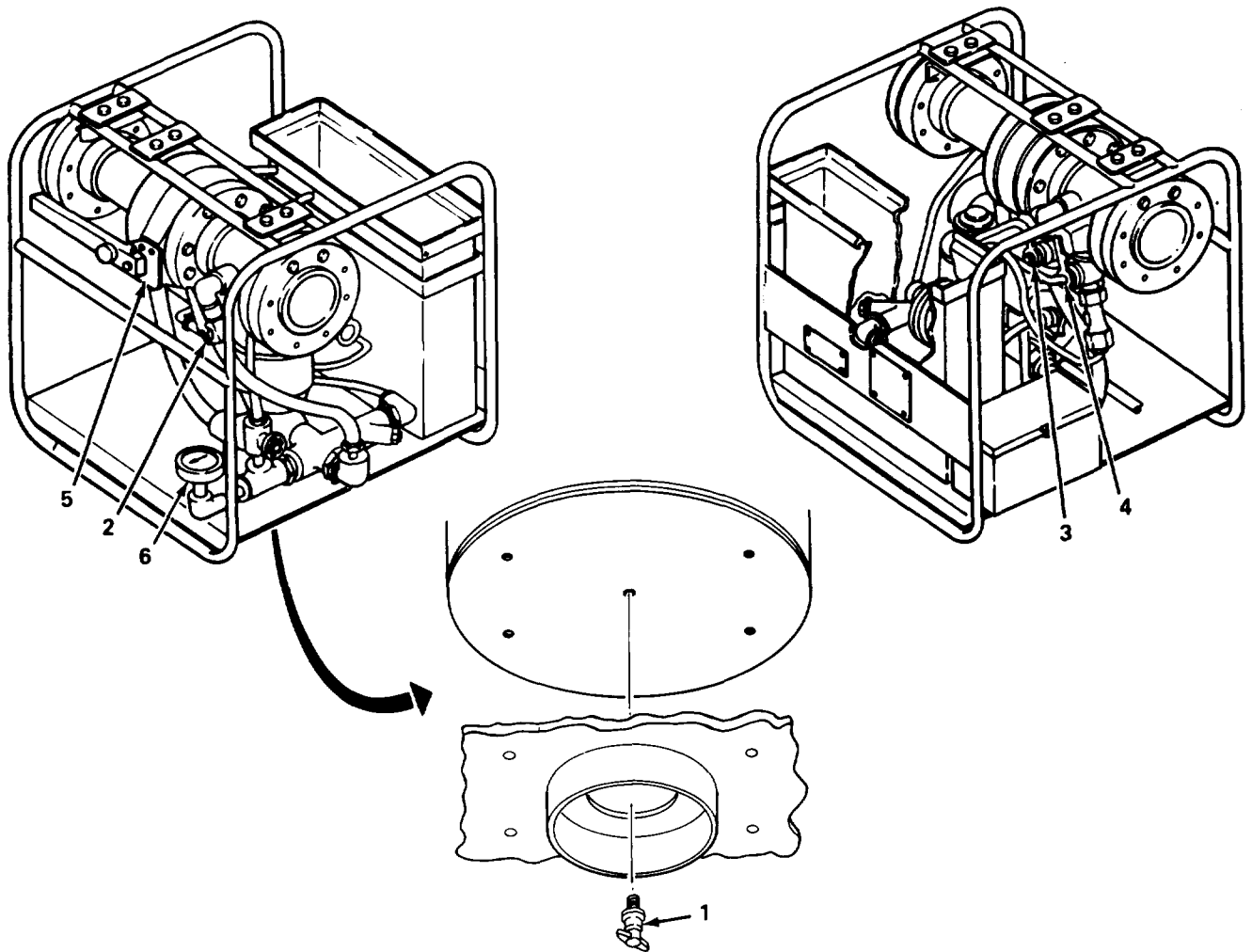

Figure 2-2. Preparation for Use and initial Startup Controls

WARNING

Hypochlorination unit weighs 241 pounds (109.3 kg). At least four people are needed to lift it to prevent personal injury or damage to the equipment.

- a. Tip hypochlorination unit and close flow controller drain cock (1).
- b. Close inlet shutoff cock (2), outlet shutoff cock (3), and hypochlorite solution shutoff cock (4).

- c. Connect hose from water supply to manifold inlet and hose from reservoir tank to manifold outlet.
- d. Fill reservoir tank with 5 gallons (18.9 liters) of clear water.

WARNING

Hypochlorite solution is toxic to skin and eyes. Avoid repeated or prolonged contact. Wear skin and eye protection to prevent personal injury.

- e. Add required ounces of calcium hypochlorination to reservoir tank for desired parts per million (ppm) dosage. (Refer to hypochlorination unit instruction plate. See figure 2-3.)
- f. Stir solution until calcium hypochlorite dissolves.

2-5. INITIAL ADJUSTMENTS.

Set solution feed pump stroke adjusting knob at 50 percent.

2-6. OPERATING PROCEDURE.

- a. Initial Startup.
 - (1) Loosen injection nozzle tube nut,
 - (2) Move foot valve assembly suction tube up and down rapidly several times to prime solution feed pump.
 - (3) Tighten injection nozzle tube nut.
 - (4) Ensure range adjusting valve (5, figure 2-2) is in fully open position (parallel to manifold flow) and insert quick-release pin to secure valve.
 - (5) With shutoff valve at water pump discharge closed, start water pump. Refer to water pump operator's manual.
 - (6) With shutoff valve downstream of hypochlorination unit closed, slowly open shutoff valve at water pump discharge.
 - (7) Slowly open valve downstream and allow water line to fill with water.
 - (8) Remove quick-release pin from range adjusting valve and set range adjusting valve for water line flow rate. Install quick-release pin to secure range adjusting valve. (Refer to hypochlorination unit instruction plate. See figure 2-3.)
 - (9) Open inlet shutoff cock (2), outlet shutoff cock (3), and hypochlorite solution shutoff cock (4).
 - (10) Check that operating pressure indicated on pressure gage (6) is between 25 and 100 psi.

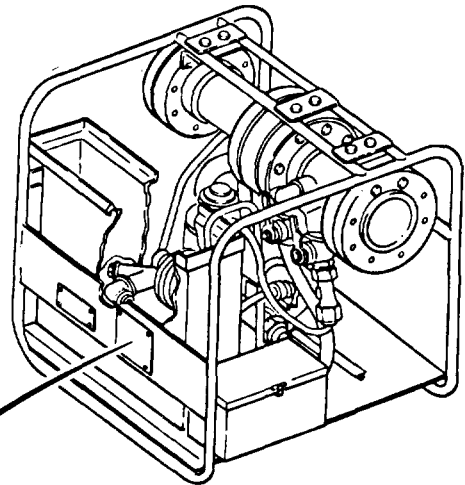

INSTRUCTIONS

HYPOCHLORINATION UNIT, WATER PURIFICATION — MODEL 1955-3

- 1 — SET MAINLINE VALVE TO PROPER POSITION BASED ON MAXIMUM EXPECTED USAGE. REFER TO INSTRUCTION MANUAL.

360-70 GPM	POSITION A
70-15 GPM	POSITION B
15-2 GPM	POSITION C
- 2 — FILL RESERVOIR TANK WITH 5 GALLONS OF WATER.
- 3 — SELECT THE REQUIRED DOSAGE IN PARTS PER MILLION (PPM).
- 4 — SELECT THE REQUIRED OUNCES OF CALCIUM HYPOCHLORITE FROM TABLE BELOW.
- 5 — ADD CALCIUM HYPOCHLORITE TO RESERVOIR TANK.
- 6 — MIX UNTIL DISSOLVED. TANK FEED TIME 2 HOURS MINIMUM.
- 7 — SET SOLUTION FEED PUMP ADJUSTING KNOB AT 50%.
- 8 — START MAINLINE FLOW.

DOSAGE PPM	1	2	3	4	5	6	7	8	9	10
360-70 GPM	8.75	17.5	26	35	44	52	61	70	78.5	87
70-15 GPM	1.75	3.7	5.2	7	8.8	10.4	12.2	14	15.7	17.4
15-2 GPM	0.4	0.8	1.1	1.5	1.9	2.2	2.6	3	3.4	3.7

Figure 2-3, Hypochlorination Unit Instruction Plate Location

b. Solution Feed Adjustment.

NOTE

- Hypochlorination unit should operate for about 5 minutes before testing.
- Conduct chlorine residual test as prescribed in TM 5-6630-215-12.

- (1) Obtain water sample for testing.
- (2) Place appropriate chlorine color disk in comparator.
- (3) Select two clean comparator cells.
- (4) Fill one cell to mark with water sample and insert cell in right-hand cell space of comparator,
- (5) Add enough of water sample to cover bottom of second cell.
- (6) Add two DPD No. 1 tablets to second cell and crush tablets using plastic rod.
- (7) Fill second cell to mark with water sample and insert cell in left-hand cell space of comparator.
- (8) Compare water color with color standards of chlorine color disk.
- (9) Record result which is closest match as value of free residual chlorine level.

NOTE

If residual chlorine level indication is too low, go to step 11.

- (10) Set solution feed pump stroke adjusting knob (6, figure 2-1) to 30 percent and go to step 12.
- (11) Set solution feed pump stroke adjusting knob to 70 percent.
- (12) Do steps 1 thru 9.

NOTE

If residual chlorine level indication is too low, go to step 14.

- (13) Add unchlorinated water to reservoir tank using tank fill valve and go to steps 15.
- (14) Adjust solution feed pump stroke adjusting knob to a slightly higher setting.
- (15) Do steps 1 thru 9 and continue to adjust solution feed pump stroke adjusting knob until achieving desired chlorine residual.

c. Refill Reservoir Tank.

- (1) Close outlet shutoff cock.

WARNING

Hypochlorite solution is toxic to skin and eyes. Avoid repeated or prolonged contact. Wear skin and eye protection to prevent personal injury.

- (2) Add required ounces of calcium hypochlorite to reservoir tank for desired ppm dosage. (Refer to hypochlorination unit instruction plate. See figure 2-3,)
 - (3) Open globe valve to refill reservoir tank with water,
 - (4) Close globe valve.
 - (5) Stir solution until calcium hypochlorite dissolves.
 - (6) Open outlet shutoff reek.
 - (7) Adjust solution feed pump if required (refer to paragraph 2-6. b).
- d. Shutdown.
- (1) Close inlet shutoff cock, outlet shutoff cock, and hypochlorite solution shutoff cock.
 - (2) Close water supply shutoff valves at water pump and downstream of hypochlorination unit.
 - (3) Shut down water pump. Refer to water pump operator's manual.
 - (4) Slowly open globe valve to vent pressure.

2-7. PREPARATION FOR MOVEMENT.

- a. Clean inlet shutoff cock, outlet shutoff cock, and hypochlorite solution shutoff cock.
- b. Close water supply shutoff valves at water pump and downstream of hypochlorination unit.
- c. Shut down water pump. Refer to water pump operator's manual.
- d. Slowly open globe valve to vent pressure.

NOTE

Retain washers during disconnection of water supply inlet and outlet for use at later time,

- e. Disconnect water supply inlet and outlet connections to manifold,

WARNING

Hypochlorite solution is toxic to skin and eyes. Avoid repeated or prolonged contact, Wear skin and eye protection to prevent personal injury.

- f. Remove reservoir fill tube from reservoir tank.
- g. Disconnect and remove liquid head assembly suction and discharge tubes.
- h. Remove reservoir tank from hypochlorination unit. Dispose of remaining solution in reservoir tank according to TM 3-250.
- i. Install reservoir tank on hypochlorination unit.

WARNING

Hypochlorination unit weighs 241 pounds (109.3 kg). At least four people are needed to lift it to prevent personal injury or damage to the equipment.

NOTE

Flow controller drain cock must remain open during movement.

- j. Tip hypochlorination unit and turn flow controller drain cock open (counterclockwise).
- k. Open inlet shutoff cock, outlet shutoff cock, and hypochlorite solution shutoff cock.

WARNING

Hypochlorination unit weighs 241 pounds (109.3 kg). At least four people are needed to lift it to prevent personal injury or damage to the equipment.

- l. Tip hypochlorination unit from side to side to drain water from hoses, tubes, and components.
- m. Install reservoir fill tube, liquid head assembly washers, and suction and discharge tubes.
- n. Install suction tube and washer to bottom of liquid pump.
- o. Install discharge tube and washer to top of liquid pump.
- p. Set range adjusting valve to fully open position (parallel to manifold) and secure with quick-release pin.

2-8. OPERATING INSTRUCTIONS ON DECALS AND INSTRUCTION PLATES. The hypochlorination unit instruction plate is located on the frame supporting the reservoir tank assembly. See figure 2-3.

Section IV. OPERATION UNDER UNUSUAL CONDITIONS**2-9. OPERATION IN UNUSUAL WEATHER.**

a. Cold Weather.

- (1) Operating the hypochlorination unit in temperatures below 32°F(0°C) requires taking precautions. Take advantage of existing shelter and windbreaks when locating equipment. Protect equipment with tent shelter. Prevent water from freezing by using fuel, coal, or wood heater or other heating device.
- (2) When equipment is shut down, drain all hoses, flow controller, and solution feed pump as soon as possible. Open all valves and check equipment closely to assure complete drainage.

b. Dusty and Sandy Areas.

- (1) Use existing shelter and windbreaks to keep sand and dirt from equipment during refill of reservoir tank assembly. Keep cover on reservoir tank assembly.
- (2) Check that water supply is protected to keep out sand and dirt.
- (3) When equipment is not in use, install dust caps on 4-inch manifold.

CHAPTER 3

OPERATOR MAINTENANCE

	Para	Page
General	3-1	3-1
Replace Chlorine Color Comparator	3-3	3-6
Troubleshooting Table	3-2	3-1

Section I. LUBRICATION INSTRUCTIONS

There are no lubrication instructions applicable to the hypochlorination unit.

Section II. OPERATOR TROUBLESHOOTING

3-1. GENERAL. Operator troubleshooting procedures for the hypochlorination unit are contained in table 3-1. Make sure that you have performed the operating procedures correctly before you perform any troubleshooting procedures. If you find that you have missed something in the operating procedures, perform the operating procedures over again to see if this will correct the problem.

3-2. TROUBLESHOOTING TABLE.

NOTE

This manual cannot list all malfunctions that may occur, nor all tests or inspections and corrective actions. If a malfunction is not listed or is not corrected by listed corrective actions, notify your supervisor.

The troubleshooting table (table 3-1) lists the common malfunctions which you may find during the operation or maintenance of the hypochlorination unit or its components. You should perform the tests/inspections and corrective actions in the order listed.

Table 3-1. Operator Troubleshooting

Malfunction
Test or inspection
Corrective action

1. SOLUTION FEED PUMP AIRLOCKED AT STARTUP

NOTE

Pump makes a distinctive thumping sound when airlocked. This sound is caused by entrapped air.

Check solution feed pump liquid head assembly for trapped air,

Table 3-1. Operator Troubleshooting - Cont

Malfunction
Test or inspection
Corrective action

1. SOLUTION FEED PUMP AIRLOCKED AT STARTUP - continued

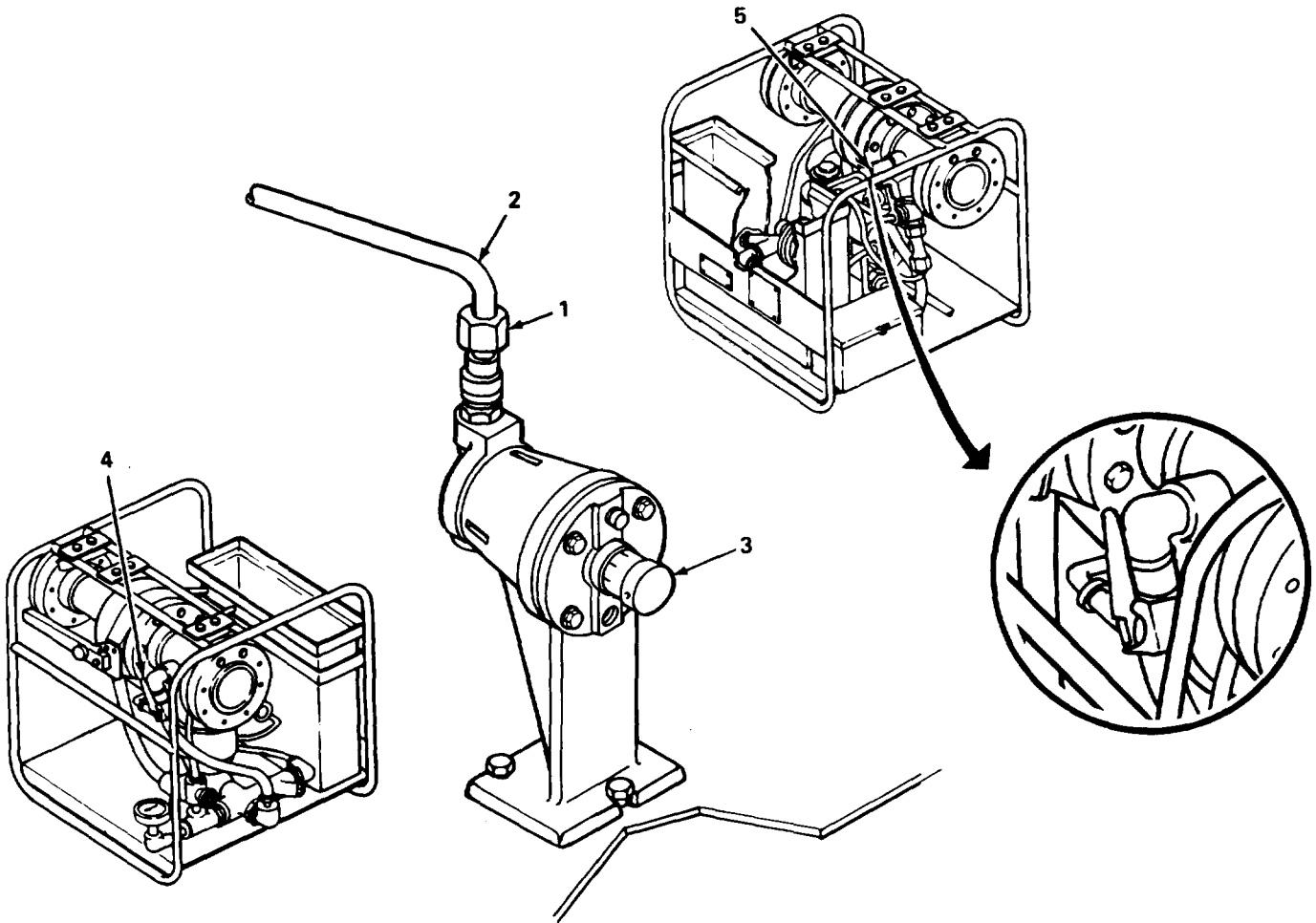

WARNING

Hypochlorite solution is toxic to skin and eyes. Do not stand directly in front of solution feed pump discharge tube. Small amounts of hypochlorite solution may be expelled in spurts. Wear skin and eye protection to prevent personal injury.

Loosen tube nut (1) on solution feed pump discharge tube (2).

Table 3-1. Operator Troubleshooting - Cont

Malfunction	
Test or inspection	
Corrective action	

1. SOLUTION FEED PUMP AIRLOCKED AT STARTUP - continued

Set solution feed pump stroke adjusting knob (3) for 100 percent.

Open inlet shutoff cock (4) and outlet shutoff cock (5).

NOTE

Allow hypochlorination unit to operate for about 2 minutes.

Tighten tube nut (1) on solution feed pump discharge tube (2).

Return to normal operation.

If malfunction still exists, notify unit maintenance.

2. CHLORINE RESIDUAL TEST INDICATES NO CHLORINE IN TREATED WATER

Step 1. Check that pressure gage indicates between 25 and 100 psi.

If pressure indication is within given limits, go to step 2.

If pressure indication is below 25 psi, refer to malfunction 4.

If pressure indication is above 100 psi, refer to malfunction 5.

Table 3-1. Operator Troubleshooting - Cont

Malfunction
Test or inspection
Corrective action

2. CHLORINE RESIDUAL TEST INDICATES NO CHLORINE IN TREATED WATER - continued

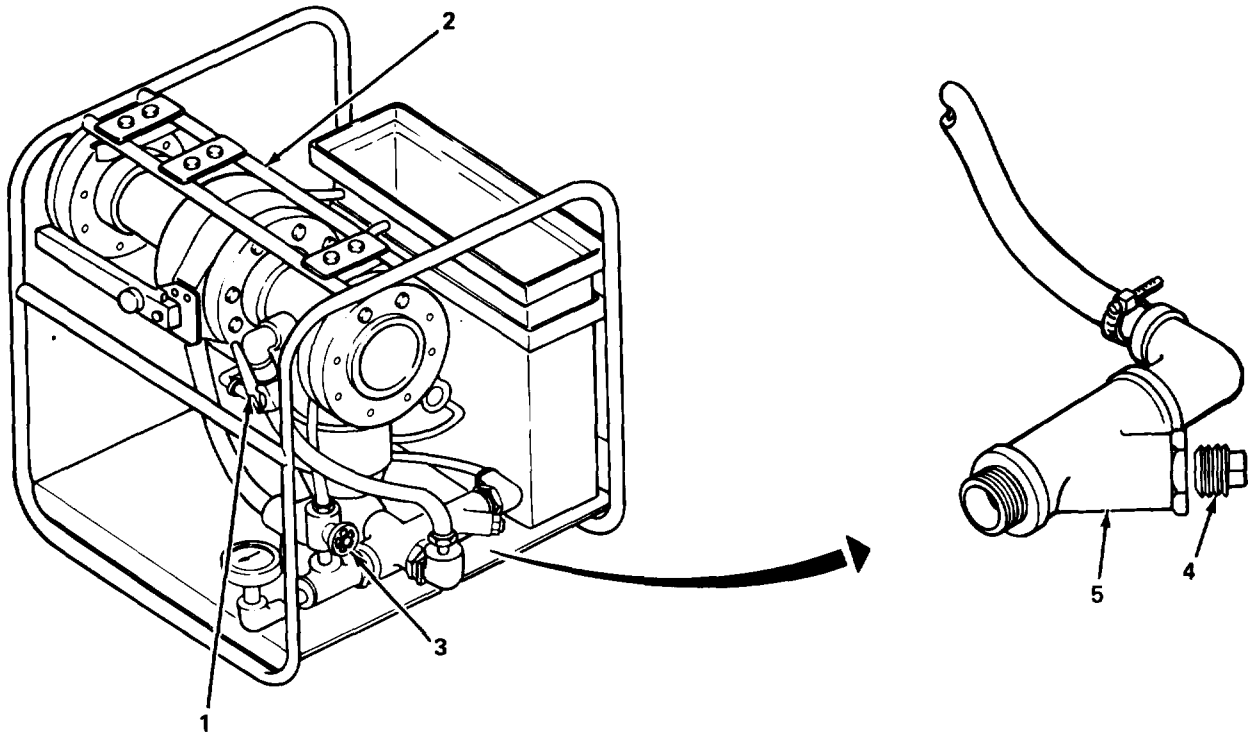

- Step 2. Check that inlet hose assembly Y-strainer is not clogged.
- Close inlet shutoff cock (1) and outlet shutoff cock (2).
- Open 1/4-inch globe valve (3).

WARNING

Water under high pressure (100 psi) is in the hypochlorination unit. Do not stand in front of Y-strainer with hypochlorination unit in operation.

- Remove plug (4) from inlet hose assembly Y-strainer (5).
- Close 1/4-inch globe valve (3).
- Open inlet shutoff cock (1) for about 3 minutes.

Table 3-1. Operator Troubleshooting - Cont

Malfunction

Test or inspection

Corrective action

2. CHLORINE RESIDUAL TEST INDICATES NO CHLORINE IN TREATED WATER - continued

Close inlet shutoff cock (1),

Install plug (4).

Return to normal operation. Refer to paragraphs 2-5 and 2-6.

If malfunction still exists, notify unit maintenance.

3. HYPOCHLORINATION UNIT LEAKS

Step 1. Check for leaks at reservoir tank assembly.

If defective, notify unit maintenance.

Step 2. Check inlet hose, outlet hose, inlet hose assembly, and outlet hose assembly for loose hose clamps.

Tighten hose clamps.

Step 3. Check for all other leaks.

Notify unit maintenance.

4. LOW PRESSURE INDICATION ON PRESSURE GAGE**NOTE**

Hypochlorination unit will operate with hydraulic pressure between 25 and 100 psi.

Step 1. Check that water supply line pump is operating.

Return pump to operation. Refer to water pump operator's manual.

Step 2. Check that waterflow in water supply line is not restricted.

Straighten water supply line.

Step 3. Check that range adjusting valve is set for water supply line flow rate.

Table 3-1. Operator Troubleshooting - Cont

Malfunction
 Test or inspection
 Corrective action

4. LOW PRESSURE INDICATION ON PRESSURE GAGE - continued

CAUTION

Verify flow rate before changing range. Failure to do so may damage equipment.

Set range adjusting valve to correction position:

<u>Waterflow Rate (gpm)</u>	<u>Position</u>
350 to 70	A
70to15	B
15to2	c

Step 4. Check that inlet and outlet shutoff cocks are open.

If inlet or outlet shutoff cock is closed, open that shutoff cock.

If inlet and outlet shutoff cocks are open, notify unit maintenance,

5. PRESSURE GAGE INDICATION GREATER THAN PRESSURE RECORDED AT STARTUP

WARNING

Water at high pressure can cause hoses to break. Use extreme care when working on equipment with water under high pressure to prevent personal injury or damage to equipment.

Check that range adjusting valve is set for water supply line flow rate.

Table 3-1. Operator Troubleshooting - Cont

Malfunction
 Test or inspection
 Corrective action

5. PRESSURE GAGE INDICATION GREATER THAN PRESSURE RECORDED AT STARTUP - continued

CAUTION

Verify flow rate before changing range. Failure to do so may damage equipment.

Set range adjusting valve to correct position:

<u>Waterflow Rate (gpm)</u>	<u>Position</u>
350 to 70	A
70 to 15	B
15 to 2	C

If malfunction still exists, notify unit maintenance.

Section III. OPERATOR MAINTENANCE PROCEDURES

3-3. REPLACE CHLORINE COLOR COMPARATOR. Replacement of the chlorine color comparator consists of inspecting for missing or damaged components and replacing as required.

CHAPTER 4

UNIT MAINTENANCE

	para	Page
Administrative Storage Requirements	4-35	4-44
Common Tools and Equipment	4-1	4-1
Explanation of Columns	4-6	4-2
General	4-5	4-2
General	4-7	4-3
Preservation, Packaging, Marking, and Shipping Requirements	4-34	4-44
Repair Check Valve.....	4-24	4-28
Repair Drain Hose Assembly	4-18	4-20
Repair Inlet Hose Assembly	4-14	4-16
Repair Manifold Assembly	4-30	4-39
Repair Outlet Hose Assembly	4-16	4-18
Repair Parts	4-3	4-2
Repair Solution Feed Pump	4-20	4-22
Repair 4-inch Manifold Assembly	4-28	4-36
Replace Antisiphon Valve	4-22	4-25
Replace Check Valve	4-23	4-27
Replace Drain Hose Assembly.....	4-17	4-19
Replace Flow Controller	4-26	4-31
Replace Foot Valve	4-21	4-23
Replace Hypochlorination Unit Frame.....	4-33	4-43
Replace Inlet and Outlet Hoses.....	4-11	4-10
Replace Inlet Hose Assembly	4-13	4-15
Replace Manifold Assembly	4-29	4-38
Replace Outlet Hose Assembly.....	4-15	4-17
Replace Pressure Gage	4-31	4-40
Replace Reservoir Tank Assembly	4-10	4-8
Replace Shutoff Cock.....	4-12	4-12
Replace Solution Feed Pump.....	4-19	4-21
Replace Solution Feed Pump Diaphragm	4-25	4-29
Replace Tool Box	4-9	4-7
Replace 1/4-inch Globe Valve	4-32	4-41
Replace 4-inch Manifold Assembly	4-27	4-34
Service Upon Receipt of Materiel.....	4-4	4-2
Special Tools, TMDE, and Support Equipment	4-2	4-2
Troubleshooting Table.....	4-8	4-3

**Section I. REPAIR PARTS; SPECIAL TOOLS; TEST, MEASUREMENT,
AND DIAGNOSTIC EQUIPMENT (TMDE); AND SUPPORT EQUIPMENT**

4-1. COMMON TOOLS AND EQUIPMENT. For authorized common tools and equipment, refer to the Modified Table of Organization and Equipment (MTOE) applicable to your unit.

4-2. SPECIAL TOOLS, TMDE, AND SUPPORT EQUIPMENT. Refer to Appendix B, Maintenance Allocation Chart, and Appendix F, Repair Parts and Special Tools List, in this manual.

4-3. REPAIR PARTS. Repair parts are listed and illustrated in Appendix F of this manual.

Section II. SERVICE UPON RECEIPT

4-4. SERVICE UPON RECEIPT OF MATERIEL.

a. Unpacking. There are no special instructions for unpacking the hypochlorination unit other than using normal care in removing the plywood box to prevent damage to the equipment and removing two dust caps from manifold.

b. Checking Unpacked Equipment.

(1) Inspect the equipment for damage incurred during shipment. If the equipment has been damaged, report the damage on DD Form 6, Packaging Improvement Report.

(2) Check the equipment against the packing slip to see if the shipment is complete. Report all discrepancies in accordance with the instructions of DA Pam 738-750.

(3) Check to see whether the equipment has been modified.

Section III. UNIT PREVENTIVE MAINTENANCE CHECKS AND SERVICES (PMCS)

4-5. GENERAL. Unit maintenance is responsible for ensuring that the hypochlorination unit is available for continuous operation. In addition to correcting the faults recorded by the operator on DA Form 2404, Equipment Inspection and Maintenance Worksheet, unit maintenance must perform the checks and services as described in table 4-1.

4-6. EXPLANATION OF COLUMNS.

a. Item No. Column. This column shows the sequence of doing the checks and services and will be used as the source of item numbers for the TM Number Column on DA Form 2404, Equipment Inspection and Maintenance Worksheet, in recording results of PMCS.

b. Interval. These columns tell you when to do a procedure. Each column that applies will contain a dot (•). Some procedures will have dots in more than one column.

c. Item To Be Inspected Column. This column contains the common name of the item to be inspected.

d. Procedures Column. This column contains a brief description of the procedure by which the check is to be performed.

Table 4-1. Unit Preventive Maintenance Checks and Services (Interval) Schedule

M - Monthly Q - Quarterly A - Annually

Item no.	Interval			Item to be inspected	Procedures
	M	Q	A		
1			•	Solution feed pump diaphragm	Inspect for splitting, cracking, and dry rot.
2		•		Flow controller	Inspect for damaged threads,
3	•			4-inch manifold	Inspect for cracks, chipping, damaged gaskets, damaged bolts and nuts, and damaged flanges.
4		•		Frame	Inspect for cracks, broken welds, and missing data plates.

Section IV. TROUBLESHOOTING

4-7. GENERAL. This manual cannot list all malfunctions that may occur, nor all tests of inspections and corrective actions. If a malfunction is not listed or is not corrected by listed corrective actions, notify your supervisor.

4-8. TROUBLESHOOTING TABLE. The troubleshooting table (table 4-2) lists the common malfunctions which you may find during the operation or maintenance of the hypochlorination unit or its components. You should perform the tests/inspections and corrective actions in the order listed.

Table 4-2. Unit Troubleshooting

Malfunction	Test or inspection	Corrective action
-------------	--------------------	-------------------

1. SOLUTION FEED PUMP AIRLOCKED AT STARTUP

WARNING

Hypochlorite solution is toxic to skin and eyes. Wear skin and eye protection to prevent personal injury.

Step 1. Check that check valves in solution feed pump suction hose and pump discharge hose are good.

Repair check valves. Refer to paragraph 4-24.

Table 4-2. Unit Troubleshooting - Cont

Malfunction

Test or inspection

Corrective action

1. SOLUTION FEED PUMP AIRLOCKED AT STARTUP - continued

Step 2. Check that solution feed pump diaphragm is good.

Replace diaphragm. Refer to paragraph 4-25.

Step 3. Check that solution feed pump is good.

Replace solution feed pump. Refer to paragraph 4-19.

2. CHLORINE RESIDUAL TEST INDICATES NO CHLORINE IN TREATED WATER

WARNING

Hypochlorite solution is toxic to skin and eyes. Wear skin and eye protection to prevent personal injury.

Step 1. Check that solution feed pump is discharging hypochlorite solution.

Close inlet shutoff cock, outlet shutoff cock, and hypochlorite solution shutoff cock.

Disconnect solution feed pump discharge hose with injection nozzle from hypochlorite solution shutoff cock.

Hold solution feed pump pump discharge hose aimed toward open reservoir tank assembly.

Open inlet shutoff cock.

Slowly open outlet shutoff cock.

Observe that hypochlorite solution is discharged into the reservoir tank assembly.

Close outlet shutoff cock and inlet shutoff cock.

If hypochlorite solution is discharged, replace antisiphon valve. Refer to paragraph 4-22.

If hypochlorite solution is not discharged, connect solution feed pump discharge hose to hypochlorite solution shutoff cock and go to step 2.

Step 2. Check that operating water is transferred to the solution feed pump.

Close inlet shutoff cock, outlet shutoff cock, and hypochlorite solution shutoff cock,

Table 4-2. Unit Troubleshooting - Cont

Malfunction	Test or inspection	Corrective action
-------------	--------------------	-------------------

2. CHLORINE RESIDUAL TEST INDICATES NO CHLORINE IN TREATED WATER - continued

Disconnect outlet hose assembly from solution feed pump.

Using a hose clamp, clamp disconnected end to hypochlorination unit frame.

WARNING

Water under high pressure (25 to 100 psi) is used in the hypochlorination unit. Do not stand in front of outlet hose assembly.

Open inlet shutoff cock.

Slowly open outlet shutoff cock.

Observe that water is discharged from outlet hose assembly.

If water is discharged, close outlet shutoff cock and inlet shutoff cock. Go to step 3.

If water is not discharged, close outlet shutoff cock and inlet shutoff cock. Go to step 4.

Step 3. Check that solution feed pump diaphragm is good. Refer to paragraph 4-25.

If diaphragm is good, replace solution feed pump. Refer to paragraph 4-19,

Step 4. Check that pressure gage indicates between 25 and 100 psi.

If pressure gage indication is within limits, replace flow controller. Refer to paragraph 4-26,

If pressure gage indication is not within given limits, replace range adjusting valve. Refer to paragraph 4-28.

3. HYPOCHLORINATION UNIT LEAKS WATER

Isolate water leak.

If inlet hose is leaking, replace inlet hose. Refer to paragraph 4-11,

If outlet hose is leaking, replace outlet hose, Refer to paragraph 4-11.

If inlet hose assembly is leaking, replace inlet hose assembly. Refer to paragraph 4-13.

If outlet hose assembly is leaking, replace outlet hose assembly. Refer to paragraph 4-15.

Table 4-2. Unit Troubleshooting - Cont

Malfunction

Test or inspection

Corrective action

3. HYPOCHLORINATION UNIT LEAKS WATER - continued

If drain hose assembly is leaking, replace drain hose assembly. Refer to paragraph 4-17.

If pressure gage is leaking, replace pressure gage. Refer to paragraph 4-31.

If reservoir tank is leaking, replace reservoir tank. Refer to paragraph 4-10.

If shutoff cock is leaking, replace shutoff cock. Refer to paragraph 4-12.

If antisiphon valve is leaking, replace antisiphon valve. Refer to paragraph 4-22.

If solution feed pump is leaking, replace solution feed pump. Refer to paragraph 4-19.

If 4-inch manifold is leaking, replace 4-inch manifold. Refer to paragraph 4-27.

If flow controller is leaking, replace flow controller. Refer to paragraph 4-26.

If 1/4-inch globe valve is leaking, replace 1/4-inch globe valve. Refer to paragraph 4-32.

4. LOW PRESSURE INDICATION ON PRESSURE GAGE

NOTE

Hypochlorination unit will operate with hydraulic pressure between 25 and 100 psi.

Check that water supply line pump is operating correctly.

Refer to water supply line pump manual.

5. PRESSURE GAGE INDICATION GREATER THAN PRESSURE RECORDED AT STARTUP

Check that range adjusting valve is good. Refer to paragraph 4-28.

Replace as required.

Section V. UNIT MAINTENANCE PROCEDURES**4-9. REPLACE TOOLBOX.**

This task covers: a. Remove. b. Inspect. c. Install.

INITIAL SETUP

- a. Tools. Tool Kit (Appx B, Sect III, Item 1).
 - b. Equipment Condition. Tools removed from tool box.
-

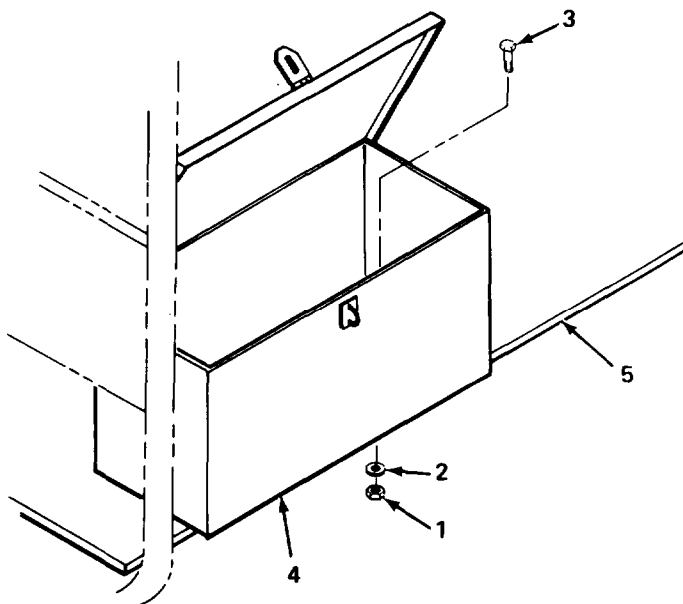
**REMOVE**

Remove two nuts (1), lockwashers (2), screws (3), and tool box (4).

INSPECT

- a. Inspect nuts and screws for damaged threads. Replace as required.
- b. Inspect tool box for cracks, damaged hinge, and broken latch. Replace as required.

INSTALL

Install tool box (4), two screws (3), lockwashers (2), and nuts(1) on hypochlorination unit (5),

END OF TASK

4-10. REPLACE RESERVOIR TANK ASSEMBLY.

This task covers:

a. Remove.

b. Inspect.

c. Install.

INITIAL SETUP

a. Tools. Tool kit (Appx B, Sect III, Item 1).

b. Equipment Condition. Hypochlorination unit shut down (paragraph 2-6.d).

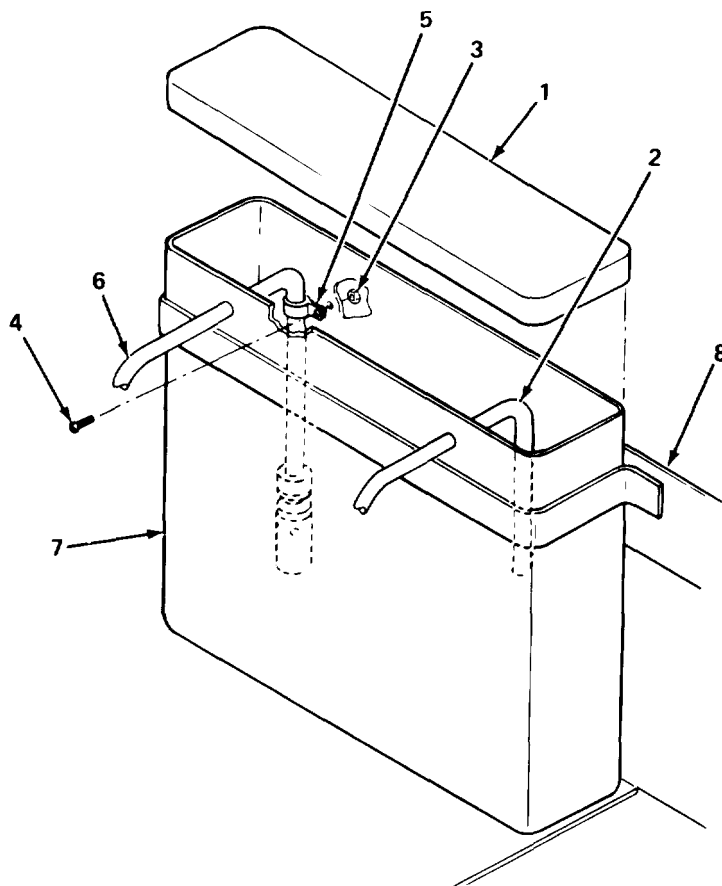

REMOVE

WARNING

Hypochlorite solution is toxic to skin and eyes. Avoid repeated or prolonged contact. Wear skin and eye protection to prevent personal injury.

a. Remove reservoir tank assembly cover (1) and fill line hose (2).

b. Remove nut (3), screw (4), clamp (5), and pump suction tube (6).

REMOVE (Cont)

- c. Remove coupling from suction tube and slide tube through tank hole. Refer to paragraph 4-21.
- d. Lift resevoir tank (7) up out of frame (8).
- e. Rinse resevoir tank with clean water.

INSPECT

- a. Inspect reservoir tank for cracks, chips, and holes. Replace as required.
- b. Inspect screw, nut, and clamp for cracks and damaged threads. Replace as required.

INSTALL

- a. Install reservoir tank (7) in frame (8).
- b. Install coupling on suction tube. Refer to paragraph 4-21.
- c. Install pump suction tube (6), clamp (5), screw (4), and nut (3).
- d. Install fill hose (2) and reservoir tank assembly cover (l).

END OF TASK

4-11. REPLACE INLET AND OUTLET HOSES.

This task covers: a. Remove. b. Inspect. c. Install.

INITIAL SETUP

- a. Tools. Tool Kit (Appx B, Sect III, Item 1).
 - b. Equipment Condition. Hypochlorination unit removed from water supply line.
-

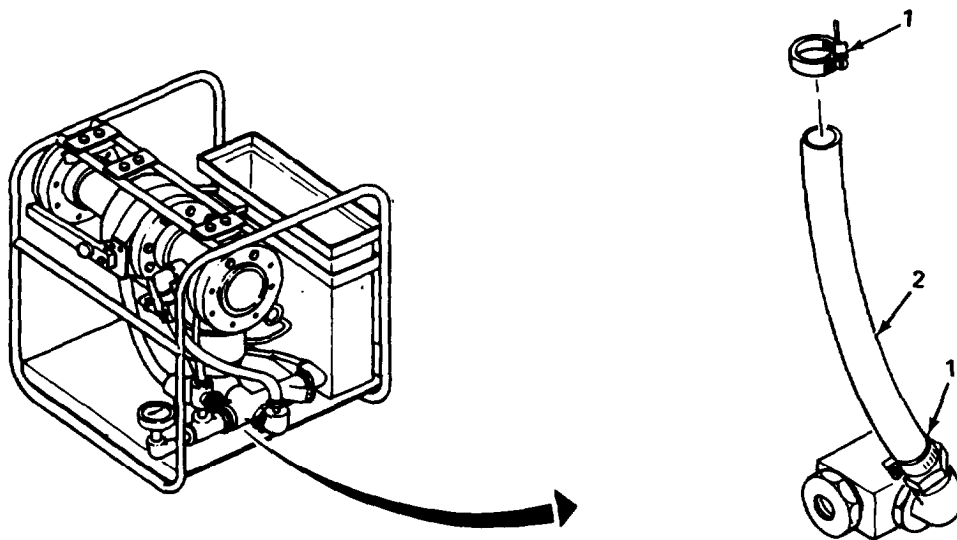

NOTE

Inlet and outlet hoses are removed and installed the same. Inlet hose is shown.

REMOVE

- a. Loosen two hose clamps (1).
- b. Remove inlet hose (2) and two hose clamps(1).

INSPECT

- a. Inspect inlet hose for cuts, cracking, and splitting. Replace as required.
- b. Inspect hose clamp for cracks and corrosion. Replace as required.

INSTALL

- a. Install two hose clamps (1) and inlet hose (2).
- b. Tighten two hose clamps (1).

END OF TASK

4-12. REPLACE SHUTOFF COCK.

This task covers:

a. Remove.

b. Inspect.

c. Install.

INITIAL SETUP

a. Tools. Tool Kit (Appx B, Sect III, Item 1).

b. Materials/Parts. Tape, Antiseize (Appx E, Sect II, Item 4).

c. Equipment Condition. Hypochlorination unit removed from water supply line.

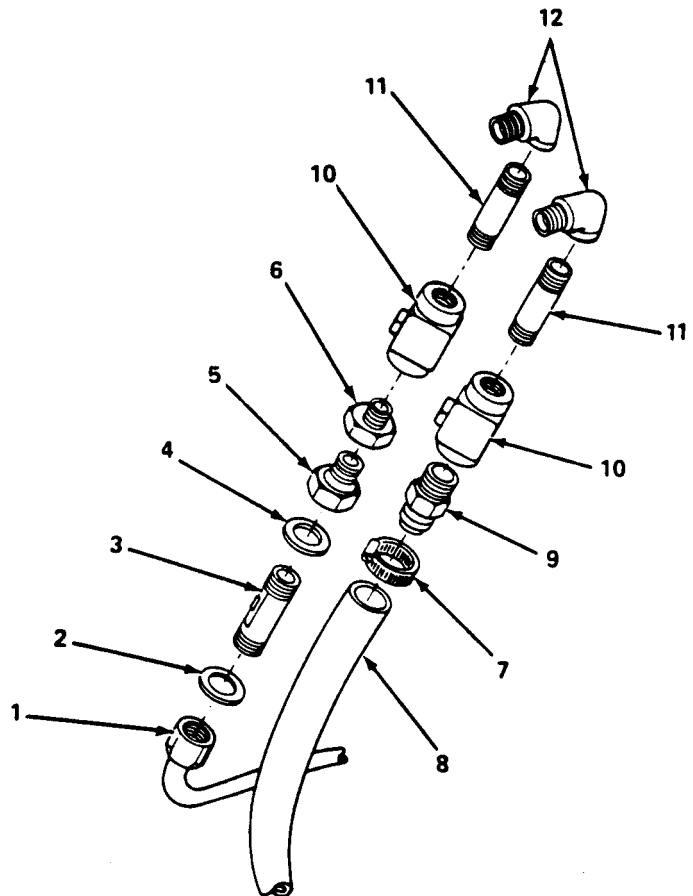
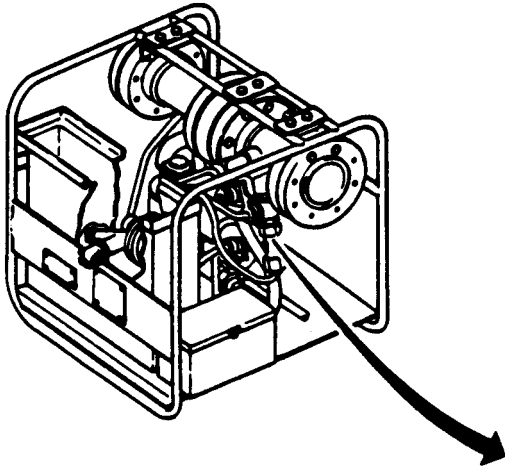

NOTE

There are three shutoff cocks. All are removed and installed the same except as noted.

REMOVE

NOTE

- If removing inlet or outlet shutoff cock, go to step d.
 - Retain washers for future use.
- a. Remove solution feed pump discharge tube (1) and washer (2).
 - b. Remove antisiphon valve (3) and washer (4).
 - c. Remove injection nozzle (5) and brass bushing (6).

NOTE

If not removing inlet or outlet shutoff cock, go to step f.

- d. Loosen hose clamp (7) and remove hose (8).
- e. Remove hose fitting (9).
- f. Remove shutoff cock (10), pipe nipple (11), and elbow (12).

INSPECT

- a. Inspect bushings, hose fittings, injection nozzle, pipe nipple, elbow, and shutoff cocks for damaged threads. Replace as required.
- b. Inspect bushing, hose fittings, injection nozzle, and shutoff cocks for cracks. Replace as required.
- c. Inspect hose clamp for cracks. Replace as required.

INSTALL

NOTE

Apply Antiseize tape to all metal-to-metal pipe connections. ■

- a. Install elbow (12), pipe nipple (11), and shutoff cock (10).

NOTE

If installing inlet or outlet shutoff cock, go to step d.

- b. Install brass bushing (6), injection nozzle (5), and washer (4).
- c. Install antisiphon valve (3), washer (2), and solution feed pump discharge tube (1).

NOTE

If not installing inlet or outlet shutoff cock, task is complete.

- d. Install hose fitting (9) and hose (8) with hose clamp (7).
- e. Tighten hose clamp (7).

END OF TASK

4-13. REPLACE INLET HOSE ASSEMBLY.

This task covers: a. Remove. b. Inspect. c. Install.

INITIAL SETUP

- a. Tools. Tool Kit (Appx B, Sect III, Item 1).
 - b. Materials/Parts. Tape, Antiseize (Appx E, Sect II, Item 4).
 - c. Equipment Condition. Hypochlorination unit removed from water supply line.
-

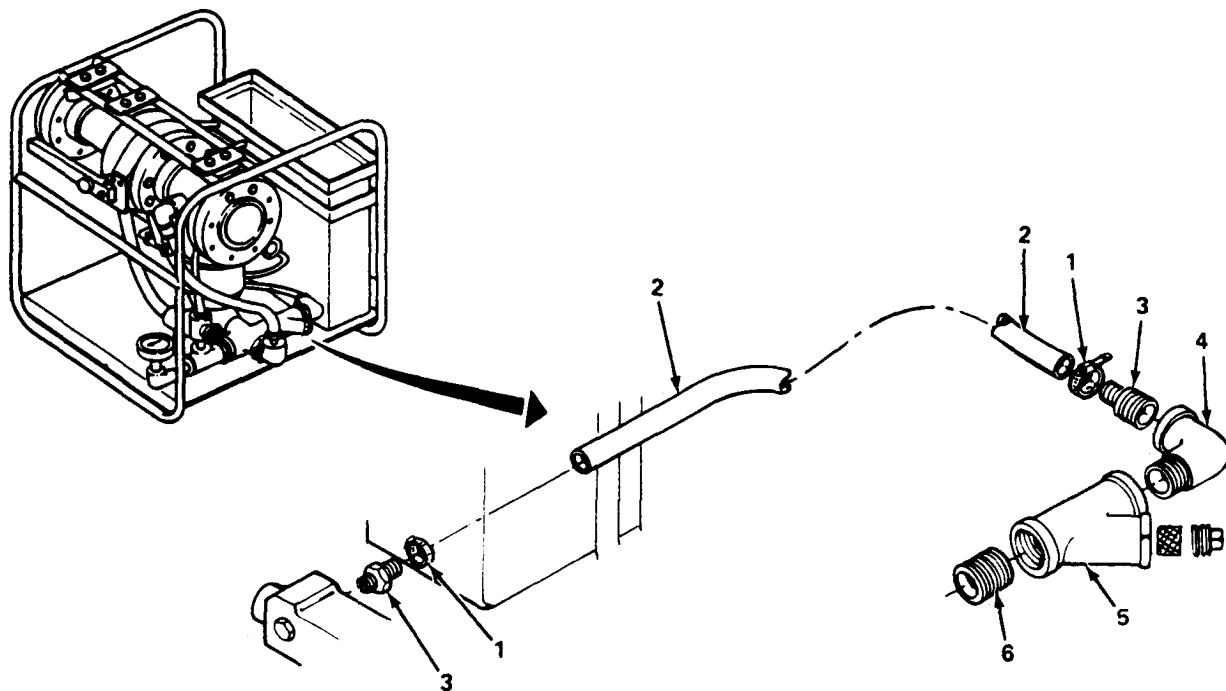
**REMOVE**

- a. Loosen two hose clamps (1).
- b. Remove tubing (2) and two hose clamps (1).
- c. Remove two hose connectors (3), street elbow (4), Y-strainer with mesh and square head plug (5), and pipe nipple (6),

INSPECT

- a. Inspect tubing for cuts, crooking, and splitting. Replace as required.
- b. Inspect hose clamp for cracks and corrosion. Replace as required.
- c. Inspect hose connectors, street elbow, and pipe nipple for damaged threads. Replace as required.
- d. Inspect strainer for damaged threads and wire mesh. Replace as required.

INSTALL

NOTE

Apply Antiseize tape to all metal to metal pipe connections.

- a. Install pipe nipple (6), strainer (5), street elbow (4), and two hose connectors (3).
- b. Install tubing (2) and two hose clamps (1).
- c. Tighten two hose clamps (1).

END OF TASK

4-14. REPAIR INLET HOSE ASSEMBLY. Repair of the inlet hose assembly is limited to replacement of components. For procedure to replace inlet hose assembly components, see Replace Inlet Hose Assembly, paragraph 4-13.

4-15. REPLACE OUTLET HOSE ASSEMBLY.

This task covers: a. Remove. b. Inspect. c. Install.

INITIAL SETUP

- a. Tools. Tool Kit (Appx B, Sect III, Item 1).
 - b. Materials/Parts. Tape, Antiseize (Appx E, Sect II, item 4).
 - c. Equipment Condition. Hypochlorination unit removed from water supply line.
-

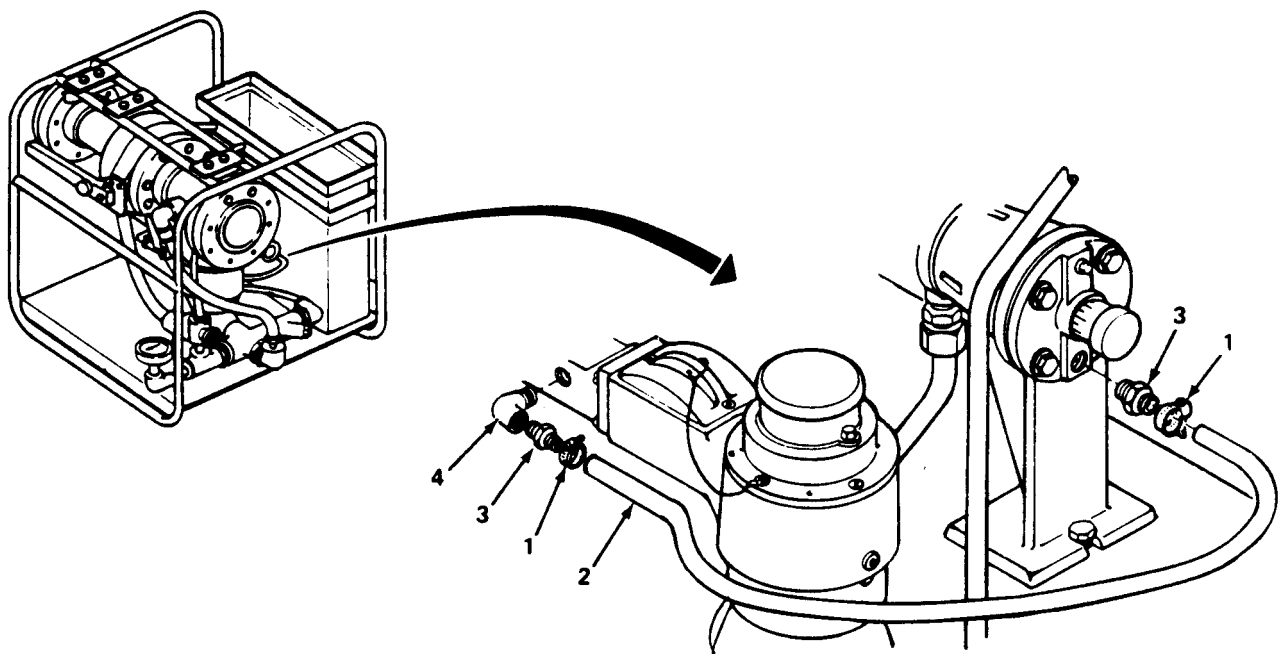
**REMOVE**

- a. Loosen two hose clamps (1).
- b. Remove tubing (2) and two hose clamps (1).
- c. Remove two hose connectors (3) and street elbow (4).

INSPECT

- a. Inspect tubing for cuts, cracking, and splitting. Replace as required.
- b. Inspect hose clamps for cracks and corrosion. Replace as required.
- c. Inspect hose connectors for damaged threads. Replace as required.

INSTALL

NOTE

Apply Antiseize tape to all metal to metal pipe connections.

- a. Install street elbow (4) and two hose connectors (3).
- b. Install tubing (2) and two hose clamps (1).
- c. Tighten two hose clamps (1).

END OF TASK

4-16. REPAIR OUTLET HOSE ASSEMBLY. Repair of the outlet hose assembly is limited to replacement of components. For procedure to replace outlet hose assembly components, see Replace Outlet Hose Assembly, paragraph 4-15.

4-17. REPLACE DRAIN HOSE ASSEMBLY.

This task covers: a. Remove. b. Inspect. c. Install.

INITIAL SETUP

- a. Tools. Tool Kit (Appx B, Sect III, Item 1).
 - b. Materials/Parts. Tape, Antiseize (Appx E, Sect II, Item 4).
 - c. Equipment Condition. Hypochlorination unit removed from water supply line.
-

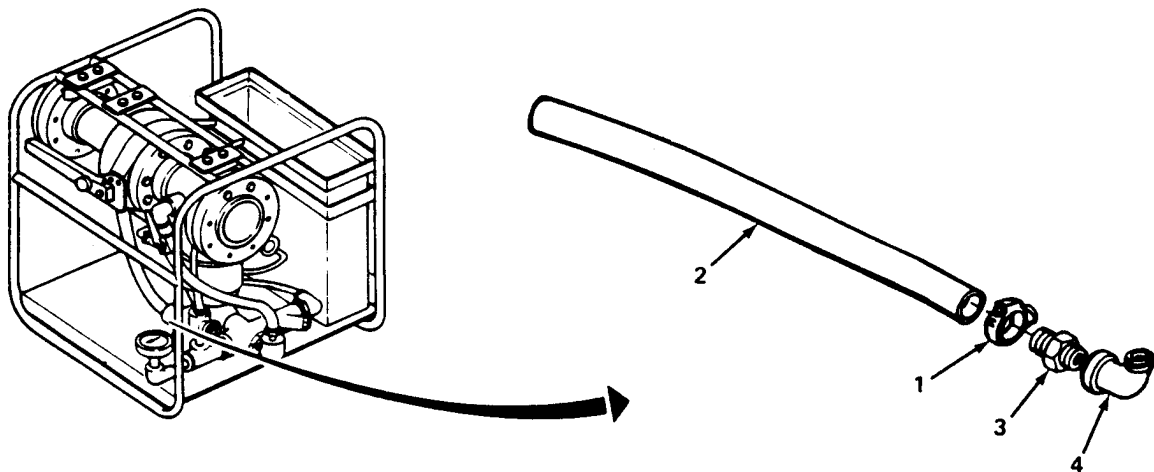
**REMOVE**

- a. Loosen hose clamp (1).
- b. Remove hose (2) and two hose clamp (1).
- c. Remove hose connector (3) and street elbow (4).

INSPECT

- a. Inspect hose for cuts, cracking, and splitting. Replace as required.
- b. Inspect hose clamps for cracks and corrosion. Replace as required.
- c. Inspect hose connector for damaged threads. Replace as required.

INSTALL

NOTE

Apply Antiseize tape to all metal to metal pipe connections.

- a. Install street elbow (4) and hose connector (3).
- b. Install hose (2) and hose clamp (1).
- c. Tighten hose clamp (1).

END OF TASK

4-18. REPAIR DRAIN HOSE ASSEMBLY. Repair of the drain hose assembly is limited to replacement of components. For procedure to replace drain hose assembly components, see Replace Drain Hose Assembly, paragraph 4-17.

4-19. REPLACE SOLUTION FEED PUMP.

This task covers:

a. Remove.

b. Inspect.

c. Install.

INITIAL SETUP

a. Tools. Tool Kit (Appx B, Sect III, Item 1).

b. Equipment Condition. Hypochlorination unit removed from water supply line.

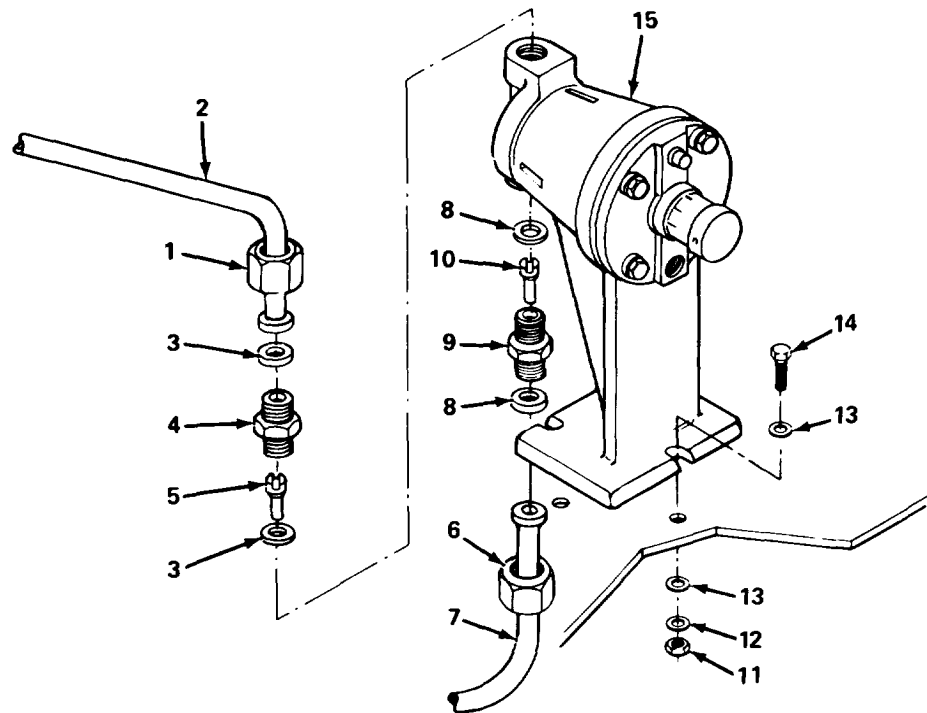
**REMOVE**

- a. Loosen tube nut (1) and remove pump discharge tube (2).
- b. Remove two check valve washers (3), check body (4), and check valve tit (5).
- c. Loosen tube nut (6) and remove pump suction tube (7).
- d. Remove two check valve washers (8), check body (9), and check valve tit (10).
- e. Remove three nuts (11), lockwashers (12), six flat washers (13), and three bolts (14).
- f. Remove solution feed pump (15).

INSPECT

- a. Inspect tube nuts, nuts, and bolts for damaged threads. Replace as required.
- b. Inspect check body for damaged threads. Replace as required.
- c. Inspect check valve washers and check valve tit for damage and wear. Replace as required.

INSTALL

- a. Install solution feed pump (15), three bolts (14), six flat washers (13), three lockwashers (12), and nuts (11).
- b. Install two check valve washers (8), check valve tit (10), and check body (9).
- c. Install pump suction tube (7) and tube nut (6).
- d. Install two check valve washers (3), check valve tit (5), and check body (4).
- e. Install pump discharge tube (2) and tube nut (1).

END OF TASK

4-20. REPAIR SOLUTION FEED PUMP. Repair of the solution feed pump is limited to replacement of components. For procedure to replace solution feed pump components, see Replace Solution Feed Pump, paragraph 4-19.

4-21. REPLACE FOOT VALVE.

This task covers:

a. Remove.

b. Inspect.

c. Install.

INITIAL SETUP

a. Tools. Tool Kit (Appx B, Sect III, Item 1).

b. Equipment Condition. Hypochlorination unit removed from water supply line.

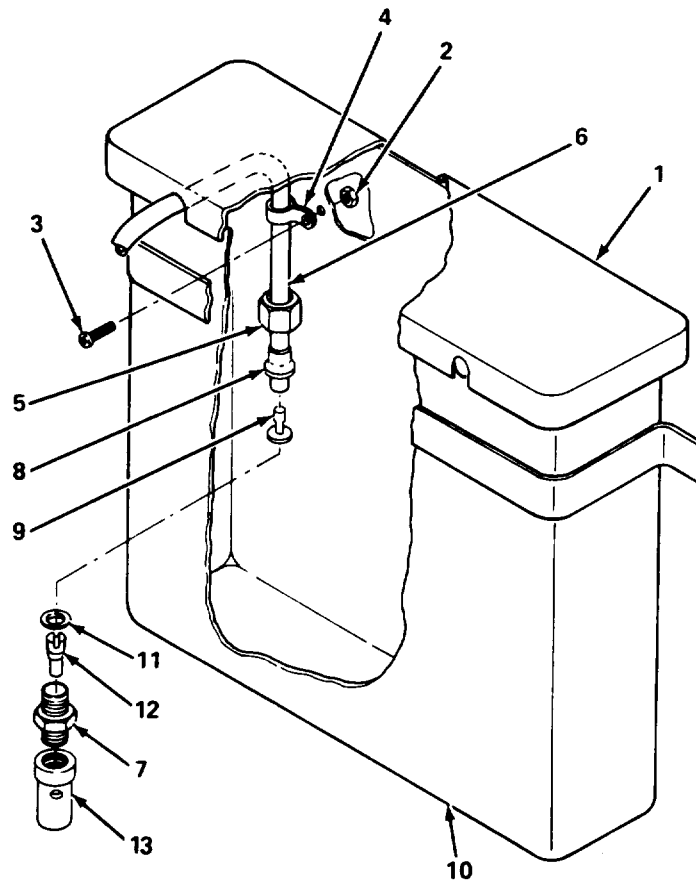

REMOVE

WARNING

Hypochlorite solution is toxic to skin and eyes. Avoid repeated or prolonged contact. Wear skin and eye protection to prevent personal injury.

a. Remove reservoir tank cover (1), nut (2), screw (3), and clamp (4).

REMOVE (Cont)

- b. Loosen tube nut (5) and separate pump suction tube (6) from check body (7).
- c. Cut pump suction tube (6) above ferrule (8) and nipple (9) and remove from reservoir tank (10).
- d. Remove check valve washer (11), check valve tit (12), and check body (7) from strainer cup (13).

INSPECT

- a. Inspect strainer cup, check body, nut, screw, and tube nut for damaged threads and corrosion. Replace as required.
- b. Inspect clamp, check valve tit, and check valve washer for damage. Replace as required.

INSTALL

WARNING

Hypochlorite solution is toxic to skin and eyes. Avoid repeated or prolonged contact. Wear skin and eye protection to prevent personal injury.

- a. Install pump suction tube (6) in reservoir tank (10).
- b. Install tube nut (5), ferrule (8), and nipple (9) on pump suction tube (6).
- c. Install check body (7) and check valve tit (12) on strainer cup (13).
- d. Install check valve washer (11), pump suction tube (6), and tube nut (5) on check body (7). Tighten tube nut (5).
- e. Install clamp (4), screw (3), nut (2), and reservoir tank cover (1).

END OF TASK

4-22. REPLACE ANTISIPHON VALVE.

This task covers: a. Remove. b. Inspect. c. Install.

INITIAL SETUP

- a. Tools. Tool Kit (Appx B, Scot III, Item 1).
 - b. Equipment Condition, Hypochlorination unit removed from water supply line.
-

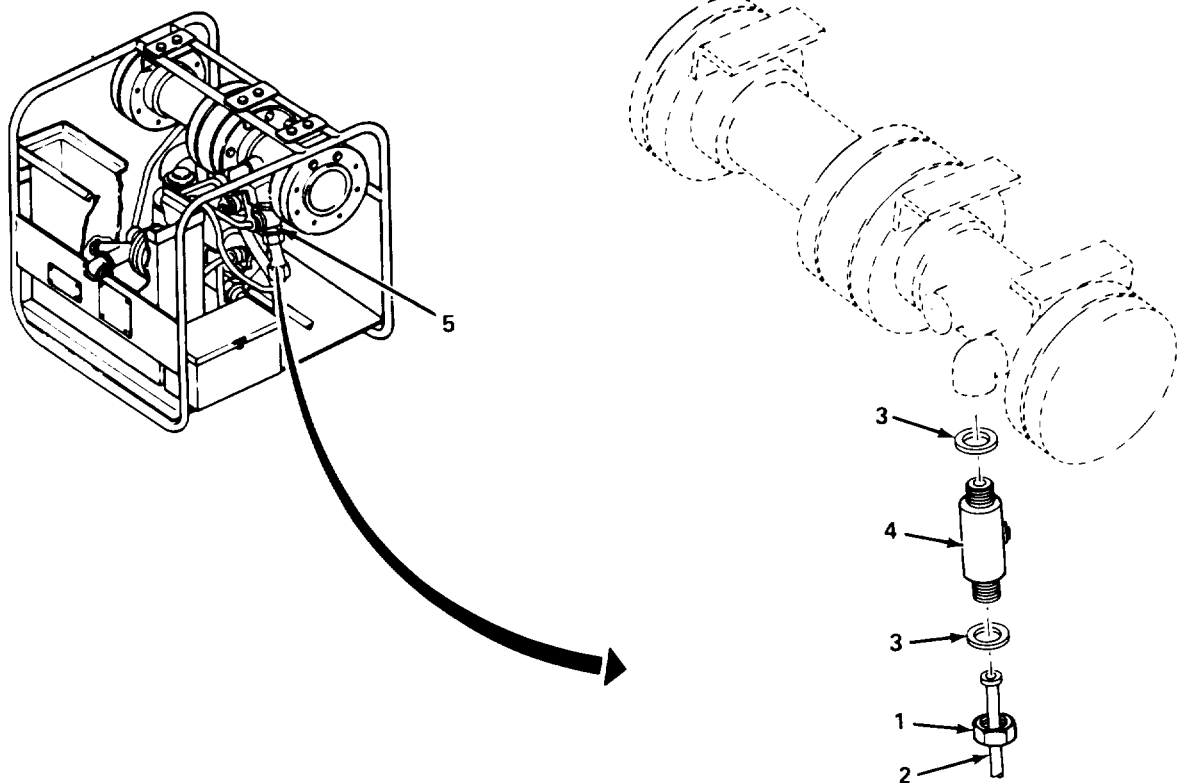

REMOVE

WARNING

Hypochlorite solution is toxic to skin and eyes. Avoid repeated or prolonged contact. Wear skin and eye protection to prevent personal injury.

- a. Loosen tube nut (1) and remove pump discharge tube (2).

REMOVE (Cont)

- b. Remove two check valve washers (3) and antisiphon valve (4).

INSPECT

- a. Inspect the tube nut and antisiphon valve for damage to threads. Replace as required.
- b. Inspect check valve washers for damage. Replace as required.

INSTALL

- a. Install two check valve washers (3) and antisiphon valve (4) on injection nozzle (5).
- b. Install pump discharge tube (2) and tube nut (1).

END OF TASK

4-23. REPLACE CHECK VALVE.

This task covers:

a. Remove.

b. Inspect.

c. Install.

INITIAL SETUP

a. Tools. Tool Kit (Appx B, Sect III, Item 1).

b. Equipment Condition. Hypochlorination unit removed from water supply line.

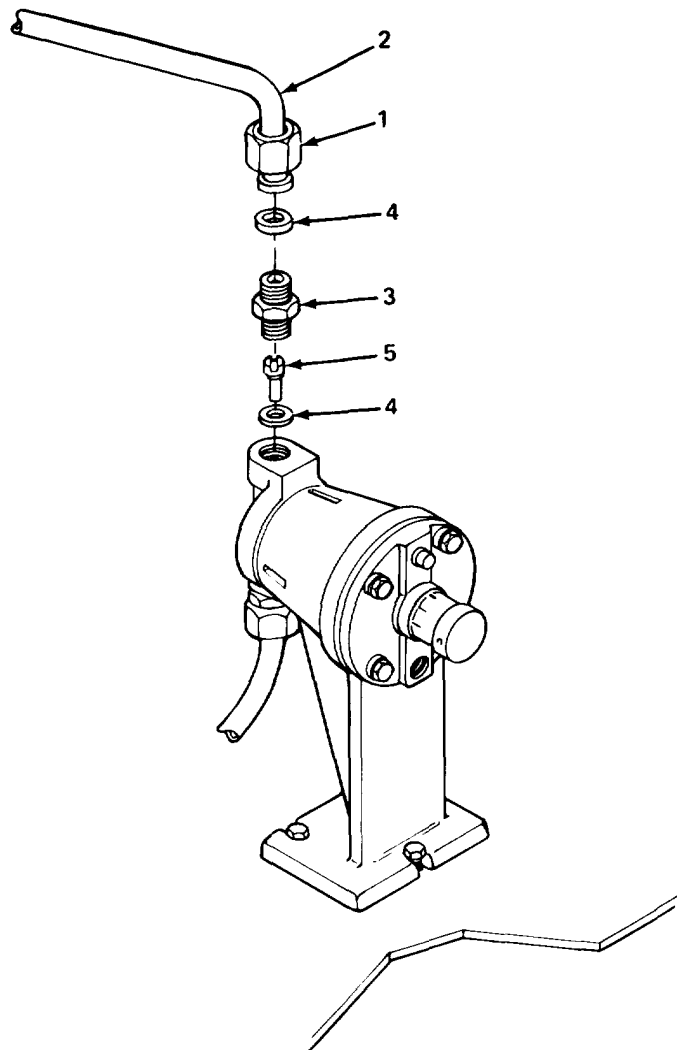

WARNING

Hypochlorite solution is toxic to skin and eyes. Avoid repeated or prolonged contact. Wear skin and eye protection to prevent personal injury.

NOTE

There are two check valves in the hypochlorination unit. Both are removed/installed the same, One is shown.

REMOVE

- a. Loosen tube nut (1) and separate pump discharge tube (2) from check body (3).
- b. Remove check valve washer (4), check valve tit (5), check body (3), and washer (4).

INSPECT

- a. Inspect check body for damaged threads. Replace as required.
- b. Inspect check valve washers and check valve tit for damage. Replace as required.

INSTALL

NOTE

Mate longest end of check body with liquid head,

- a. Install check valve washer (4), check body (3), check valve tit (5), and washer (4).
- b. Install pump discharge tube (2) and tube nut (1).

END OF TASK

4-24. REPAIR CHECK VALVE. Repair of the check valve is limited to replacement of components. For procedure to replace check valve components, see Replace Check Valve, paragraph 4-23.

4-25. REPLACE SOLUTION FEED PUMP DIAPHRAGM.

This task covers: a. Remove. b. Inspect. c. Install.

INITIAL SETUP

- a. Tools. Tool Kit (Appx B, Sect III, Item 1).
 b. Equipment Condition. Hypochlorination unit shut down (paragraph 2-6.d).
 Tool box removed (paragraph 4-9).
-

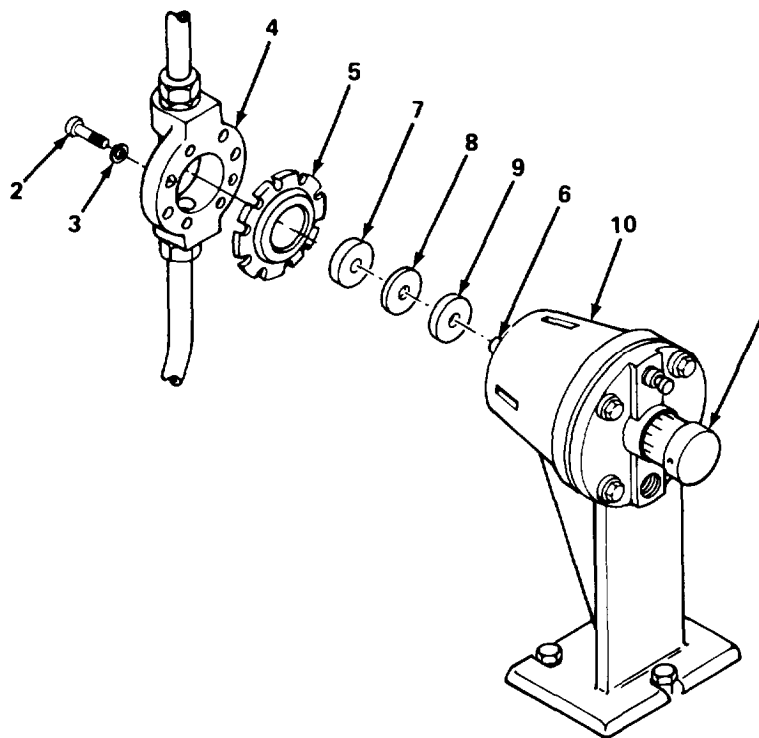
**REMOVE****WARNING**

Hypochlorite solution is toxic to skin and eyes. Avoid repeated or prolonged contact. Wear skin and eye protection to prevent personal injury.

- a. Adjust pump stroke adjusting knob (1) to 0.
- b. Remove eight screws (2) and lockwashers (3) and liquid head assembly (4).
- c. Unscrew diaphragm (5) from push rod (6).
- d. Remove push plate (7), flat washer (8), and spacer (9) from diaphragm (5).

INSPECT

- a. Inspect diaphragm for cracking and tears. Replace as required.
- b. Inspect screws for damaged threads. Replace as required.

INSTALL

NOTE

Small face of push plate goes next to diaphragm.

- a. Install push plate (7), flat washer (8), and spacer (9) on diaphragm (5).
- b. Install diaphragm (5) on push rod (6).
- c. Aline slotted holes at edge of diaphragm (5) with screw holes in pump frame (10).

NOTE

Arrow on liquid head assembly must point up.

- d. Install liquid head assembly (4), eight screws (2), and lockwashers (3).

END OF TASK

4-26. REPLACE FLOW CONTROLLER.

This task covers: a. Remove. b. Inspect. c. Install.

INITIAL SETUP

- a. Tools. Tool Kit (Appx B, Sect III, Item 1).
- b. Materials/Parts. Tape, Antiseize (Appx E, Sect II, Item 4).
- c. Equipment Condition. Outlet hose assembly removed (paragraph 4-15).
 Drain hose assembly removed (paragraph 4-17).

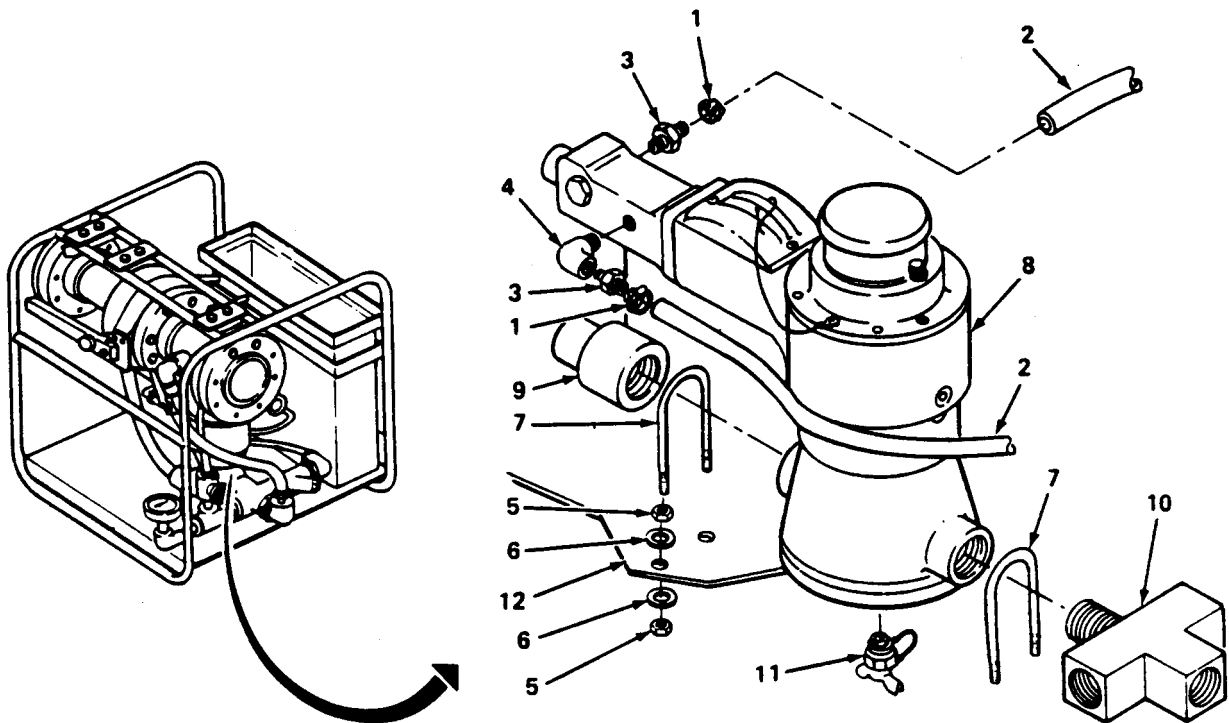

REMOVE

- a. Loosen two hose clamps (1).
- b. Remove two tubes (2), hose clamps (1) and hose connectors (3).
- c. Remove street elbow (4).
- d. Remove eight nuts (5) and flat washers (6) and two U-bolts (7).

REMOVE (Cont)

WARNING

The hypochlorination flow controller is heavy/difficult to handle. Two people are needed to lift it to prevent personal injury or damage to the equipment.

- e. Remove flow controller (8).
- f. Remove brass reducer coupling (9) and brass cross (10) from flow controller (8).
- g. Remove drain cock assembly (11).

INSPECT

- a. Inspect hose clamps and flat washers for cracks and corrosion. Replace as required.
- b. Inspect hose connectors, brass reducer coupling, and brass cross for damaged threads and cracks. Replaced as required.
- c. Inspect nuts and U-bolts for damaged threads and corrosion. Replace as required.
- d. Inspect drain cock assembly for damaged threads, ease of operation, and clogged port. Replace as required.

INSTALL

NOTE

Apply Antiseize tape to all metal to metal pipe connections.

- a. Install drain cock assembly (11), brass reducer coupling (9), and brass cross (10) on flow controller (8).

WARNING

The hypochlorination flow controller is heavy/difficult to handle. Two people are needed to lift it to prevent personal injury or damage to the equipment.

- b. Install flow controller (8) on hypochlorination unit (12).
- c. Install two U-bolts (7) and eight flat washers (6) and nuts (5).
- d. Install street elbow (4).
- e. Install two hose connectors (3), hose clamps (1), and tubes (2).
- f. Tighten two hose clamps (1).

INSTALL (Cont)

g. Install outlet hose assembly. Refer to paragraph 4-15.

h. Install drain hose assembly. Refer to paragraph 4-17.

END OF TASK

4-27. REPLACE 4-INCH MANIFOLD ASSEMBLY.

This task covers: a. Remove. b. Inspect. c. Install.

INITIAL SETUP

- a. Tools. Tool Kit (Appx B, Sect III, Item 1).
 - b. Materials/Parts. Tape, Antiseize (Appx E, Sect II, Item 4).
 - c. Equipment Condition. Shutoff cocks removed (paragraph 4-12).
 - d. Personnel Required. 2
-

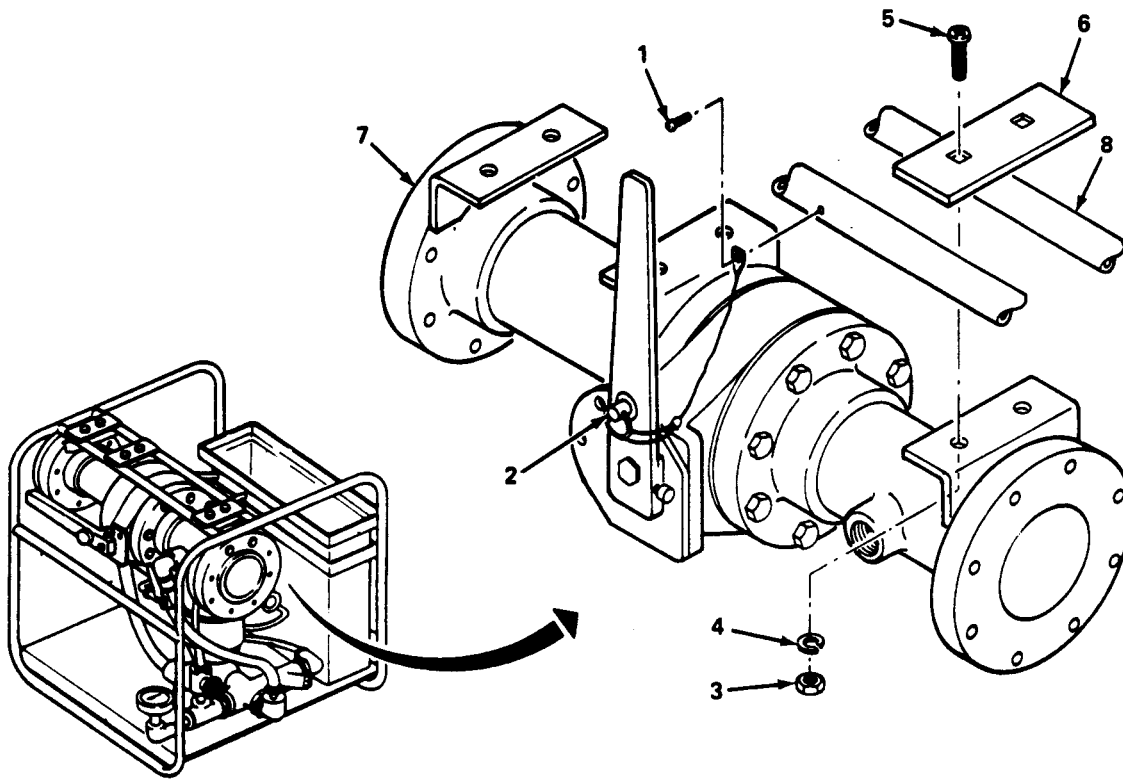

REMOVE

- a. Remove screw (1) and quick-release pin (2).

WARNING

The 4-inch manifold assembly is heavy/difficult to handle. Two people are needed to lift it to prevent personal injury or damage to the equipment.

- b. Remove six nuts (3), lockwashers (4), bolts (5), and three brackets (6).
- c. Remove 4-inch manifold assembly (7).

INSPECT

- a. Inspect bolts and nuts for damaged threads and corrosion. Replace as required.
- b. Inspect brackets for cracks and corrosion. Replace as required.

INSTALL

WARNING

The 4-inch manifold assembly is heavy/difficult to handle. Two people are needed to lift it to prevent personal injury or damage to the equipment.

NOTE

Apply Antiseize tape to all metal to metal pipe connections.

- a. Position 4-inch manifold assembly (7) on hypochlorination unit (8).
- b. Install three brackets (6) and six bolts (5), lockwashers (4), and nuts (3).
- c. Install quick-release pin (2) and screw (1).
- d. Install shutoff cocks. Refer to paragraph 4-12.

END OF TASK

4-28. REPAIR 4-INCH MANIFOLD ASSEMBLY.

This task covers: a. Disassemble. b. Inspect. c. Assemble.

INITIAL SETUP

- a. Tools. Tool Kit (Appx B, Sect III, Item 1).
- b. Equipment Condition. 4-inch manifold assembly removed (paragraph 4-27).

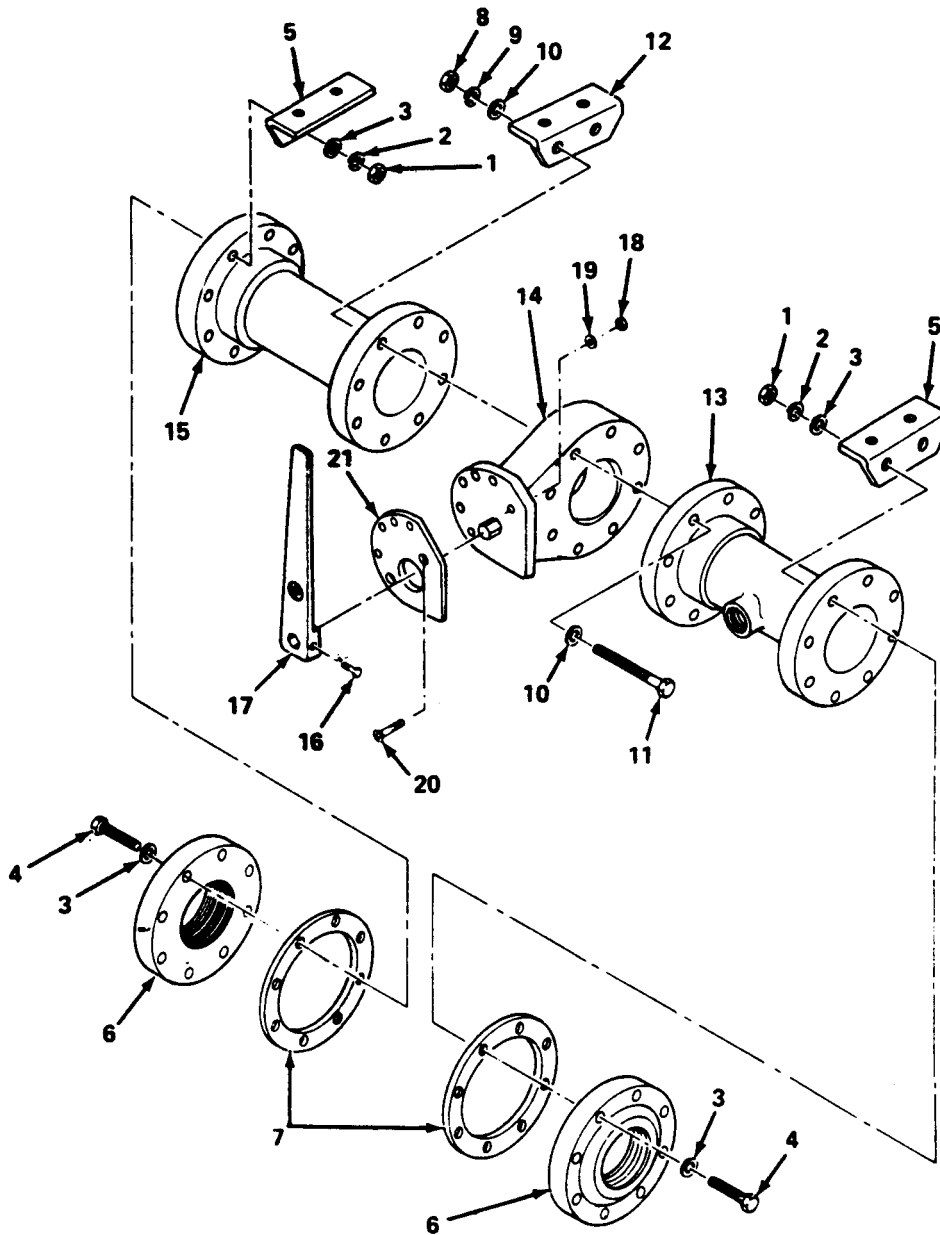

DISASSEMBLE

- a. If required, remove 16 nuts (1) and lockwashers (2), 32 washers (3), 16 bolts (4), and 2 brackets (5).
- b. Remove two flanges (6) and gaskets (7).
- c. Remove 8 nuts (8) and lockwashers (9), 16 washers (10), 8 bolts (11), and bracket (12).
- d. Remove spool (13) and butterfly valve (14) from spool (15).
- e. Remove screw (16) and handle (17).
- f. Remove two nuts (18), washers (19), screws (20), and stop plate (21).

INSPECT

- a. Inspect screws, bolts, and nuts for damaged threads. Replace as required.
- b. Inspect gaskets for cuts, breaks, and wear. Replace as required.
- c. Inspect spools for cracks, chipping, and damaged threads. Replace as required.
- d. Inspect flanges for breaks, cracks, and dents. Replace as required.
- e. Inspect butterfly valve for bent or broken vanes, cracks, bent or broken shaft, and hard to turn shaft. Replace as required.
- f. Inspect handle for cracks and damaged threads. Replace as required.
- g. Inspect stop plate for cracks, readability, and deformities. Replace as required.

ASSEMBLE

- a. Install stop plate (21) and two screws (20), washers (19), and nuts (18) on butterfly valve (14).
- b. Install handle (17) and screw (16) on butterfly valve (14).
- c. Install butterfly valve (14) and spool (13) on spool (15).
- d. Install bracket (12), 8 bolts (11), 16 washers (10), 8 lockwashers (9), and nuts (8).
- e. Install two gaskets (7) and flanges (6).
- f. Install 2 brackets (5), 16 bolts (4), 32 washers (3), 16 lockwashers (2), and nuts (1).

END OF TASK

4-29. REPLACE MANIFOLD ASSEMBLY.

This task covers: a. Remove. b. Inspect. c. Install.

INITIAL SETUP

- a. Tools. Tool Kit (Appx B, Sect III, Item 1).
 - b. Materials/Parts. Tape, Antiseize (Appx E, Sect II, Item 4).
 - c. Equipment Condition. Inlet hose removed (paragraph 4-11).
 Inlet hose assembly removed (paragraph 4-13).
 Pressure gage removed (paragraph 4-31).
 Globe valve removed (paragraph 4-32).
-

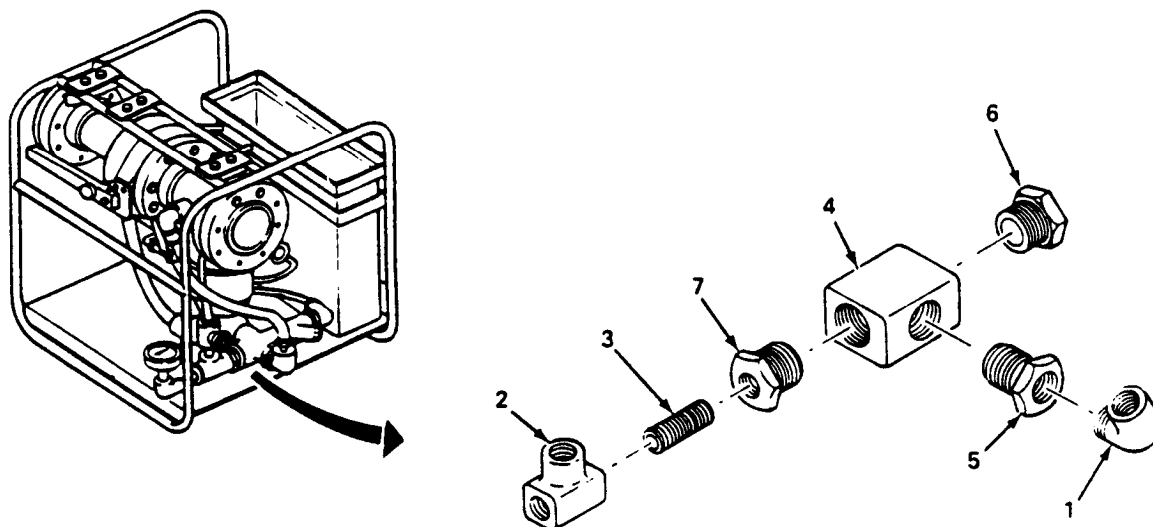

REMOVE

- a. Remove street elbow (1), brass tee (2), brass nipple (3), and brass cross (4).
- b. Remove three brass. reducer bushings (5, 6, and 7) from brass cross (4).

INSPECT

Inspect street elbow, brass tee, brass nipple, brass cross. and three brass reducer bushings for damaged threads and cracks. Replace as required.

INSTALL

NOTE

Apply Antiseize tape to all metal to metal pipe connections.

- a. Install three brass reducer bushings (5, 6, and 7) in brass cross (4).

INSTALL (Cont)

- b. Install brass cross (4), brass nipple (3), brass tee (2), and street elbow (1).
- c. Install globe valve. Refer to paragraph 4-32.
- d. Install pressure gage. Refer to paragraph 4-31.
- e. Install inlet hose assembly. Refer to paragraph 4-13.
- f. Install inlet hose. Refer to paragraph 4-11.

END OF TASK

4-30. REPAIR MANIFOLD ASSEMBLY. Repair of the manifold assembly is limited to replacement of components. For procedure to replace manifold assembly components, see Replace Manifold Assembly, paragraph 4-29.

4-31. REPLACE PRESSURE GAGE.

This task covers: a. Remove. b. Inspect. c. Install.

INITIAL SETUP

- a. Tools. Tool Kit (Appx B, Sect III, Item 1).
 - b. Materials/Parts. Tape, Antiseize (Appx E, Sect II, Item 4).
 - c. Equipment Condition. Hypochlorination unit removed from water supply line.
-

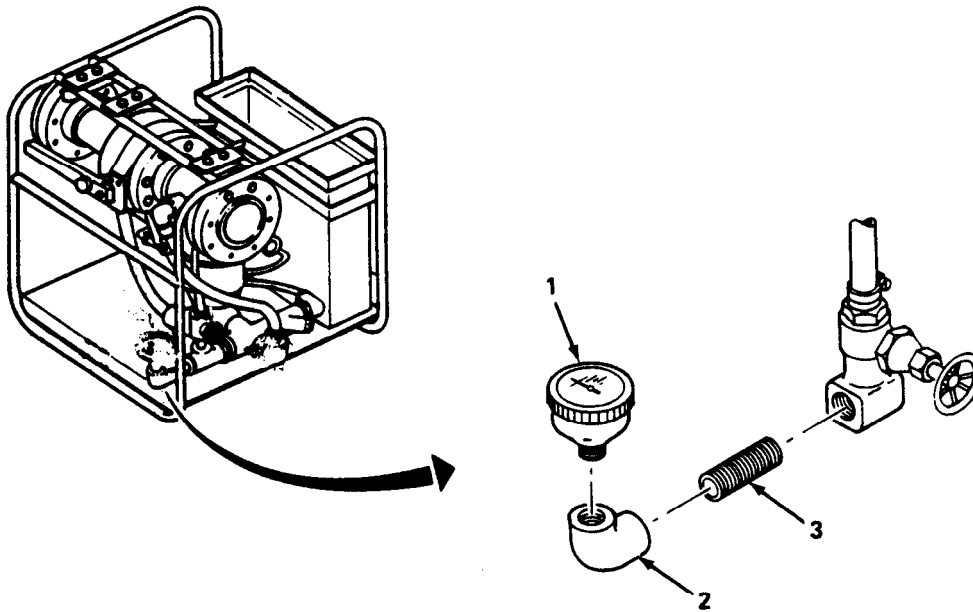

REMOVE

Remove pressure gage (1), brass elbow (2), and brass nipple (3).

INSPECT

Inspect pressure gage, brass elbow, and brass nipple for damaged threads and cracks. Replace as required.

INSTALL

NOTE

Apply Antiseize tape to all metal to metal pipe connections.

Install pressure gage (1), brass elbow (2), and brass nipple (3).

END OF TASK

4-32. REPLACE 1/4-INCH GLOBE VALVE.

 This task covers:

a. Remove.

b. inspect.

c. Install.

INITIAL SETUP

a. Tools, Tool Kit (Appx B, Sect III, Item 1).

b. Materials/Parts. Tape, Antiseize (Appx E, Sect III, Item 4)

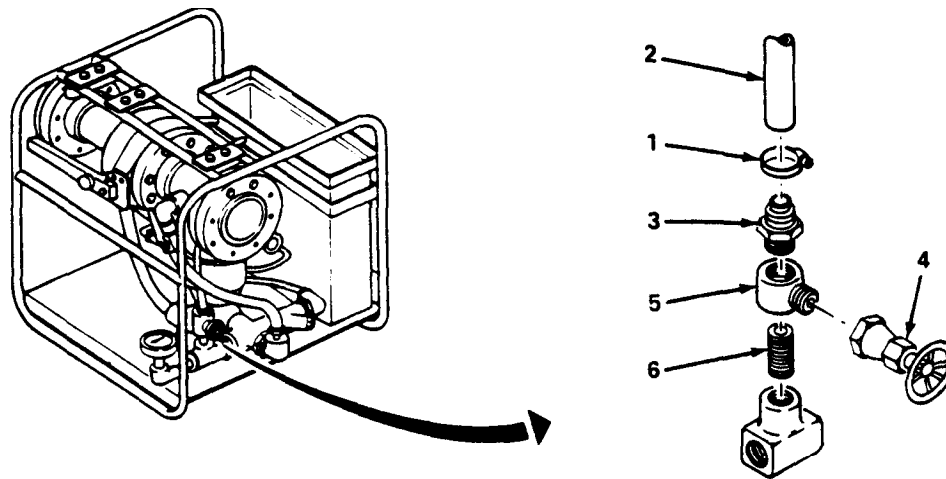
**REMOVE**

- a. Loosen hose clamp (1).
- b. Remove tubing (2) and hose clamp (1).
- c. Remove hose connector (3).
- d. Remove globe valve bonnet (4).
- e. Remove globe valve body (5) and brass nipple (6)

INSPECT

- a. Inspect hose connector, globe valve body, globe valve bonnet, and brass nipple for damaged threads and cracks. Replace as required.
- b. Inspect tubing for cuts, cracking, and splitting. Replace as required.
- c. Inspect hose clamp for cracks and corrosion. Replace as required.

INSTALL

NOTE

Apply Antiseize tape to all metal to metal pipe connections.

- a. Install brass nipple (6) and globe valve body (5).
- b. Install globe valve bonnet (4) and hose connector (3).
- c. Install tubing (2) and hose clamp (1).
- d. Tighten hose clamp (1).

END OF TASK

4-33. REPLACE HYPOCHLORINATION UNIT FRAME.

This task covers: a. Remove. b. Inspect. c. Install.

INITIAL SETUP

- a. Tools. Tool Kit (Appx B, Sect III, Item 1).
 - b. Materials/Parts. Tape, Antiseize (Appx E, Sect II, Item 4).
 - c. Equipment Condition. Hypochlorination unit removed from water supply line.
-

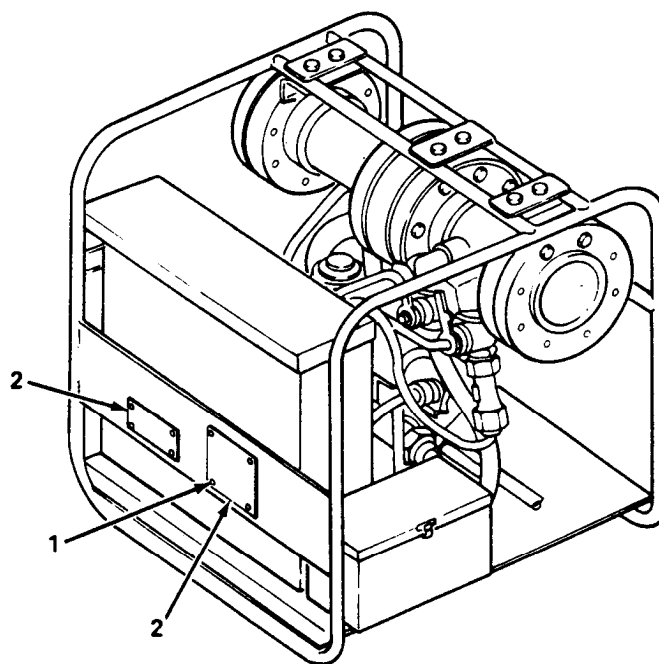
**REMOVE**

- a. Remove tool box. Refer to paragraph 4-9.
- b. Remove reservoir tank assembly. Refer to paragraph 4-10.
- c. Remove solution feed pump. Refer to paragraph 4-19.
- d. Remove flow controller. Refer to paragraph 4-26.
- e. Remove manifold assembly. Refer to paragraph 4-29.
- f. Remove eight screws (1) and two name plates (2).

INSPECT

- a. Inspect frame for breaks, cracks, holes, broken welds, and dents. Replace as required.
- b. Inspect name plates for damage. Replace as required.

INSTALL

- a. Install two name plates (2) and eight screws (1).
- b. Install flow controller. Refer to paragraph 4-26.
- c. Install solution feed pump. Refer to paragraph 4-19.
- d. Install manifold assembly. Refer to paragraph 4-29.
- e. Install reservoir tank assembly. Refer to paragraph 4-10.
- f. Install tool box. Refer to paragraph 4-9.

END OF TASK

Section VI. PREPARATION FOR STORAGE OR SHIPMENT

4-34. PRESERVATION, PACKAGING, MARKING, AND SHIPPING REQUIREMENTS. Refer to MIL-P-116 for preservation, packaging, marking, and shipping requirements.

4-35. ADMINISTRATIVE STORAGE REQUIREMENTS. Administrative storage of equipment issued to and used by Army activities will have preventative maintenance performed in accordance with the PMCS charts before storing. When removing the equipment from administrative storage, the PMCS should be performed to assure operational readiness.

CHAPTER 5

DIRECT SUPPORT MAINTENANCE

	Para	Page
Introduction	5-1	5-1
Repair Cover	5-3	5-1
Repair Frame	5-2	5-1

5-1. INTRODUCTION. This chapter contains maintenance procedures performed by direct support maintenance and authorized by the maintenance allocation chart.

5-2. REPAIR FRAME.

INITIAL SETUP

- a. Tools. Field Maintenance Welding Shop Equipment (Appx B, Sect III, Item 2).

For welding procedures, refer to TM 9-237.

For repair of metal bodies, refer to TM 9-450.

END OF TASK

5-3. REPAIR COVER.

This task covers: a. Inspect, b. Repair.

INITIAL SETUP

- a. Tools. Refer to FM 43-3.
- b. Equipment Condition. Cover removed from equipment.

INSPECT

- a. Spread cover flat on a clean surface. Ensure outside of cover is up.
- b. Check that rim strip around edge of cover is not coming unstitched.
- c. Mark loose stitching for repair.
- d. Check cover for tears. Mark for repair.
- e. Check that ropes are not frayed or missing, Replace as required.

INSPECT (Cont)

f. Check that brass eyelets are not missing. Replace as required.

REPAIR

a. Sew patches on tears. Refer to FM43-3.

b. Sew loose rim strip. Refer to FM43-3.

c. Replace brass eyelets. Refer to FM 43-3.

END OF TASK

APPENDIX A

REFERENCES

A-1. SCOPE. This appendix lists all forms, field manuals, technical manuals, and miscellaneous publications referenced in this manual.

A-2. FORMS.

- Recommended Changes to Publications and Blank FormsDA Form 2028
- Recommended Changes to Equipment Technical manuals.DA Form 2028-2
- Equipment Inspection and Maintenance Worksheet. DA Form 2404
- Packaging Improvement Report. DD Form 6
- Quality Deficiency Report Form SF 368

A-3. FIELD MANUALS.

- First Aid for Soldiers FM 21-11
- General Repair for Canvas and Webbing FM 43-3

A-4. TECHNICAL MANUALS.

- Storage, Shipment, Handling, and Disposal of Chemical Agents and Hazardous
Chemicals TM 3-250
- Operator's and Organizational Maintenance Manual for Water Quality Analysis/Sets:
Preventive Medicine TM5-6630-215-12
- Operator's Manual: Welding Theory and ApplicationTM 9-237
- Metal Body Repair and Related OperationsTM 9-450
- Destruction of Army Materiel to Prevent Enemy UseTM 750-244-3

A-5. MISCELLANEOUS.

- The Army Maintenance Management System (TAMMS)DA Pam 738-750
- Preservation, Methods of MIL-P-116

APPENDIX B

MAINTENANCE ALLOCATION CHART

Section I. INTRODUCTION

B-1. GENERAL.

a. This section provides a general explanation of all maintenance and repair functions authorized at various maintenance categories.

b. The Maintenance Allocation Chart (MAC) in Section II designates overall authority and responsibility for the performance of maintenance functions on the identified end item or component. The application of the maintenance functions to the end item or component will be consistent with the capacities and capabilities of the designated maintenance categories.

c. Section III lists the tools and test equipment (both special tools and common tool sets) required for each maintenance function as referenced from Section II.

d. Section IV contains supplemental instructions and explanatory notes for a particular maintenance function.

B-2. MAINTENANCE FUNCTIONS. Maintenance functions will be limited to and defined as follows:

a. *Inspect.* To determine the serviceability of an item by comparing its physical, mechanical, and/or electrical characteristics with established standards through examination; e.g., by sight, sound, or feel.

b. *Test.* To verify serviceability by measuring the mechanical, pneumatic, hydraulic, or electrical characteristics of an item and comparing those characteristics with prescribed standards.

c. *Service.* Operations required periodically to keep an item in proper operating condition; i.e., to clean (includes decontaminate, when required), to preserve, to drain, to paint, or to replenish fuel, lubricants, chemical fluids, or gases.

d. *Adjust.* To maintain or regulate, within prescribed limits, by bringing into proper or exact position, or by setting the operating characteristics to specified parameters.

e. *Aline.* To adjust specified variable elements of an item to bring about optimum or desired performance.

f. *Calibrate.* To determine and cause corrections to be made or to be adjusted on instruments or test, measuring, and diagnostic equipments used in precision measurement. Consists of comparisons of two instruments, one of which is a certified standard of known accuracy, to detect and adjust any discrepancy in the accuracy of the instrument being compared.

g. *Remove/install.* To remove and install the same item when required to perform service or other maintenance functions. Install may be the act of emplacing, seating, or fixing into position a spare, repair part, or module (component or assembly) in a manner to allow the proper functioning of an equipment or system.

h. *Replace.* To remove an unserviceable item and install a serviceable counterpart in its place. "Replace" is authorized by the MAC and is shown as the third position code of the SMR code.

i. Repair. The application of maintenance services, including fault location/troubleshooting, removal/installation, and disassembly/assembly procedures, and maintenance actions to identify troubles and restore serviceability to an item by correcting specific damage, fault, malfunction, or failure in a part, subassembly, module (component or assembly), end item, or system.

j. Overhaul. That maintenance effort (service/action) prescribed to restore an item to a completely serviceable/operational condition as required by maintenance standards in appropriate technical publications; i.e., DMWR. Overhaul is normally the highest degree of maintenance performed by the Army. Overhaul does not normally return an item to like new condition.

k. Rebuild. Consists of those services/actions necessary for the restoration of unserviceable equipment to a like new condition in accordance with original manufacturing equipment, The rebuild operation includes the act of returning to zero those age measurements (hours/miles, etc.) considered in classifying Army equipment/components.

B-3. EXPLANATION OF COLUMNS IN THE MAC, SECTION II

a. Column 1, Group Number. Column 1 lists functional group code numbers, the purpose of which is to identify maintenance significant components, assemblies, subassemblies, and modules with the next higher assembly. End item group number shall be "00."

b. Column 2, Component/Assembly. Column 2 contains the names of components, assemblies, subassemblies, and modules for which maintenance is authorized.

c. Column 3, Maintenance function. Column 3 lists the functions to be performed on the item listed in Column 2. (For detailed explanation of these functions, see paragraph B-2.)

d. Column 4, Maintenance Category. Column 4 specifies, by the listing of a work time figure in the appropriate subcolumn(s), the category of maintenance authorized to perform the function listed in Column 3. This figure represents the active time required to perform that maintenance function at the indicated category of maintenance. If the number or complexity of the tasks within maintenance function varies at different maintenance categories, appropriate work time figures will be shown for each category. The work time figure represents the average time required to restore an item (assembly, subassembly, component, module, end item, or system) to a serviceable condition under typical field operating conditions. This time includes preparation time (including any necessary disassembly/assembly time), troubleshooting/fault location time, and quality assurance/quality control time in addition to the time required to perform the specific tasks identified for the maintenance functions authorized in the maintenance allocation chart. The symbol designations for the various maintenance categories are as follows:

- C - Operator or crew
- O - Unit maintenance
- F - Direct support maintenance
- H - General support maintenance
- D - Depot maintenance

e. Column 5, Tools and Equipment. Column 5 specifies, by code, those common tool sets (not individual tools) and special tools, TM DE, and support equipment required to perform the designated function.

f. Column 6, Remarks. This column shall, when applicable, contain a letter code, in alphabetic order, which shall be keyed to the remarks contained in Section IV.

B-4. EXPLANATION OF COLUMNS IN TOOL AND TEST EQUIPMENT REQUIREMENTS, SECTION III.

a. Column 1, Reference Code. The tool and test equipment reference code correlates with a code used in the MAC, Section II, Column 5.

b. Column 2, Maintenance Category. The lowest category of maintenance authorized to use the tool or test equipment.

c. Column 3, Nomenclature. Name or identification of the tool or test equipment.

d. Column 4, National Stock Number. The National stock number of the tool or test equipment

e. Column 5, Tool Number. The manufacturer's part number.

B-5. EXPLANATION OF COLUMNS IN REMARKS, SECTION IV.

a. Column 1, Reference Code. The code recorded in Column 6, Section II.

b. Column 2, Remarks. This column lists information pertinent to the maintenance function being performed as indicated in the MAC, Section II.

Section II. MAINTENANCE ALLOCATION CHART
FOR
WATER PURIFICATION HYPOCHLORINATION UNIT, MODEL 1955-3

(1) Group Number	(2) Component/ Assembly	(3) Maintenance Function	(4) Maintenance Category					(5) Tools and Eqpt.	(6) Remarks
			Unit		DS	GS	Depot		
			C	O	F	H	D		
00	HYPOCHLORINA- TION UNIT, WATER PURI- FICATION	Inspect	0.1	0.1				1,2	
Service		0.1							
Replace			0.5						
		Repair			2.5				
0001	COVER	Inspect	0.1	0.1					
Replace			0.1						
Repair					1.0				
0002	BOX, TOOL	Inspect	0.1	0.1				1	
Replace				0.5					
0003	TANK ASSEMBLY, RESERVOIR	Inspect	0.1						
Replace				0.3					
Repair					0.5				
0004	HOSE, INLET	Inspect	0.1	0.1				1	
Replace				0.5					
0005	HOSE, OUTLET	Inspect	0.1	0.1				1	
Replace				0.5					
Repair					0.5				
0006	SHUTOFF COCK, 3/4-INCH	Inspect	0.1	0.1				1	
Replace				1.0					
0007	HOSE ASSEMBLY, INLET	Inspect	0.1	0.1				1	
Replace				0.5					
Repair					0.5				
0008	HOSE ASSEMBLY, OUTLET	Inspect	0.1	0.1				1	
Replace				0.5					
Repair					0.5				
0009	HOSE ASSEMBLY, DRAIN	Inspect	0.1	0.1				1	
Replace				0.5					
Repair					0.5				
01	SOLUTION FEED PUMP, MODEL 1261	Inspect	0.1	0.1				1	
Replace				0.5					
Repair					1.5				

**Section II. MAINTENANCE ALLOCATION CHART
FOR
WATER PURIFICATION HYPOCHLORINATION UNIT, MODEL 1955-3**

(1) Group Number	(2) Component/ Assembly	(3) Maintenance Function	(4) Maintenance Category					(5) Tools and Eqpt.	(6) Remarks
			Unit		DS	GS	Depot		
			C	O	F	H	D		
0101	VALVE ASSEMBLY FOOT	Inspect Replace	0.1	0.1 0.5				1	
0102	VALVE ANTI- SIPHON	Inspect Replace	0.1	0.1 0.5				1	
0103	VALVE, CHECK	Inspect Replace Repair	0.1	0.1 0.5 1.0				1 1	
0104	DIAPHRAGM	Inspect Replace		0.1 1.5				1	
02	FLOW CONTROLLER	Inspect Replace Repair	0.1	0.1 1.0				1	A
03	MANIFOLD ASSEMBLY, 4-INCH	Inspect Replace Repair	0.1	0.1 1.0 1.0				1 1	
04	MANIFOLD ASSEMBLY WITH PRESSURE GAGE, GLOBE VALVE, AND FILL HOSE	Inspect Replace Repair	0.1	0.1 1.0 1.0				1 1	
0401	GAGE, PRES- SURE	Inspect Replace	0.1	0.1 0.5				1	
0402	VALVE, 1/4-INCH GLOBE	Inspect Replace	0.1	0.1 1.0				1	
05	FRAME, HYPO- CHLORINATION UNIT	Inspect Replace Repair	0.1	0.1 4.0	1.0			1	B
06	COMPARATOR, CHLORINE COLOR	Inspect Replace	0.1 0.2						

Section VI. TOOLS AND TEST EQUIPMENT REQUIREMENTS

TOOL OR TEST EQUIPMENT REF CODE	MAINTENANCE CATEGORY	NOMENCLATURE	NATIONAL/NATO STOCK NUMBER	TOOL NUMBER
1	O,F	Tool Kit, General Mechanic's (W45060) or equivalent	5180-00-699-5273	
2	F	Shop Equipment, Welding, Field, Maintenance	3470-00-357-7268	

Section VII. REMARKS

REFERENCE CODE	REMARKS
A	Return unit to Direct Support Maintenance (for collection at New Cumberland Army Depot and forwarding to manufacturer for repair).
B	Repair by welding at Direct Support Maintenance.

APPENDIX C

COMPONENTS OF END ITEM AND BASIC ISSUE ITEMS LISTS

Section I. INTRODUCTION

C-1. SCOPE. This appendix lists components of end item and basic issue items for the hypochlorination unit to help you inventory items required for safe and efficient operation.

C-2. GENERAL. The Components of End Item and Basic Issue Items Lists are divided into the following sections:

a. Section II, Components of End Item (COEI). This listing is for informational purposes only and is not authority to requisition replacements. These items are part of the end item, but are removed and separately packaged for transportation or shipment. As part of the end item, these items must be with the end item whenever it is issued or transferred between property accounts. Illustrations are furnished to assist you in identifying the items.

b. Section III, Basic Issue Items (BII). These are the minimum essential items required to place the hypochlorination unit in operation, to operate it, and to perform emergency repairs. Although shipped separately packaged, BII must be with the hypochlorination unit during operation and whenever it is transferred between property accounts. The illustrations will assist you with hard-to-identify items. This manual is your authority to request/requisition replacement BII, based on TOE/MTOE authorization of the end item.

C-3. EXPLANATION OF COLUMNS. The following provides an explanation of columns found in the tabular listings:

a. Column (1), Illustration Number (Illus Number). This column indicates the number of the illustration in which the item is shown.

b. Column (2), National Stock Number. Indicates the National stock number assigned to the item and will be used for requisitioning purposes,

c. Column (3), Description. Indicates the Federal item name and, if required, a minimum description to identify and locate the item. The last line for each item indicates the CAGE (in parentheses) following by the part number.

d. Column (4), Unit of Measure (U/M). Indicates the measure used in performing the actual operational/maintenance function. This measure is expressed by a two-character alphabetical abbreviation; e.g., ea, in, pr.

e. Column (5), Quantity Required (Qty Reqd). Indicates the quantity of the item authorized to be used with/on the equipment.

Section II. COMPONENTS OF END ITEM

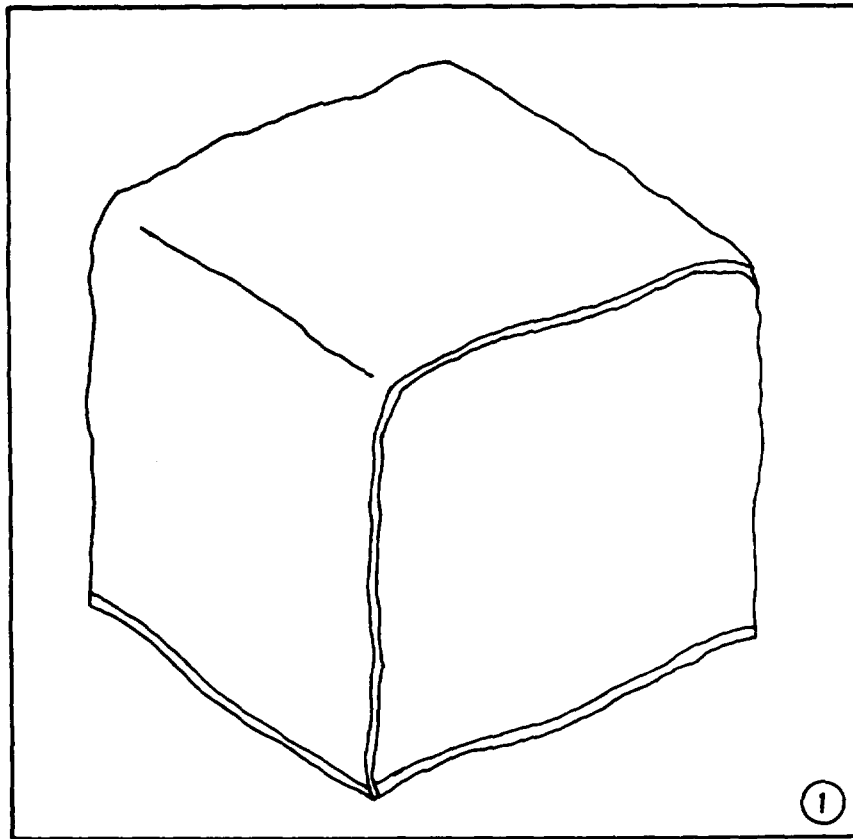

(1) Illus Number	(2) National Stock Number	(3) Description CAGE and Part Number	(4) U/M	(5) Qty Reqd
1		COVER (71 229) C-245249	EA	1

Section III. BASIC ISSUE ITEMS

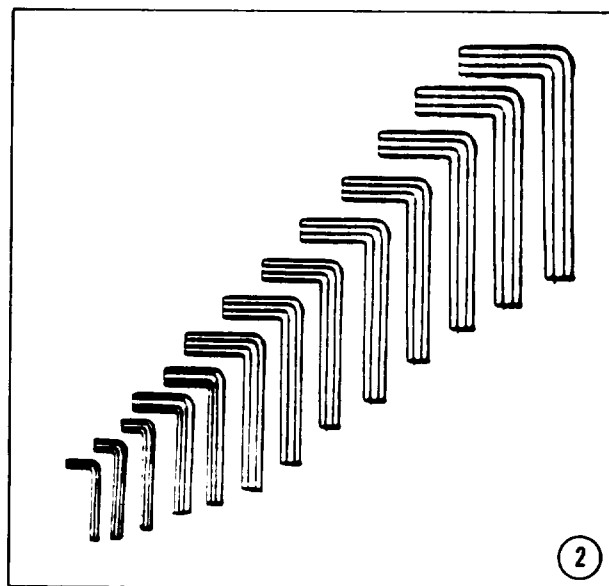
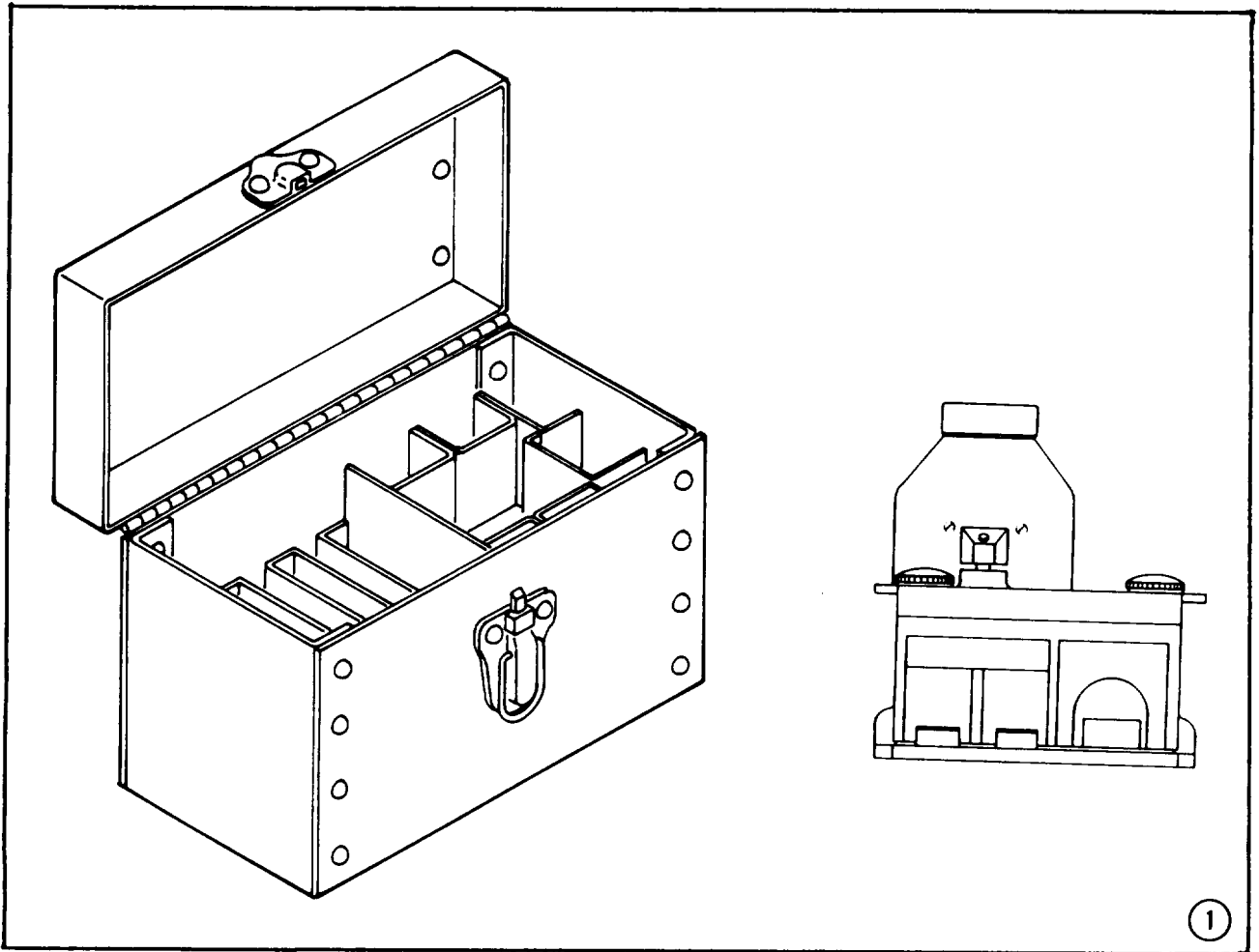

(1) Illus Number	(2) National Stock Number	(3) Description CAGE and Part Number	(4) U/M	(5) Qty Reqd
1	6630-01-044-0334	COMPARATOR, CHLORINE COLOR (1 2308) U25337	EA	1
2		KEY SET, SOCKET HEAD (71 229) D-249685	ST	1

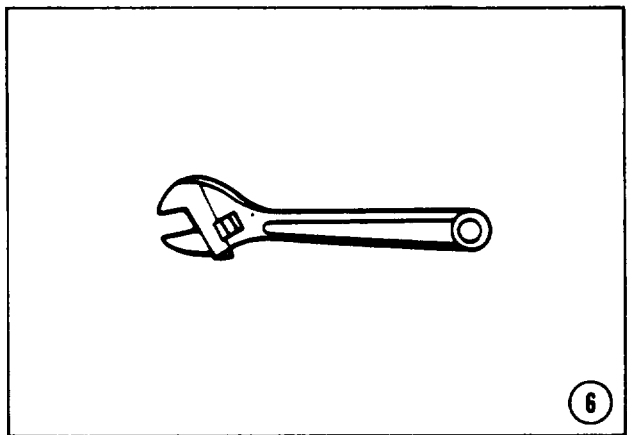
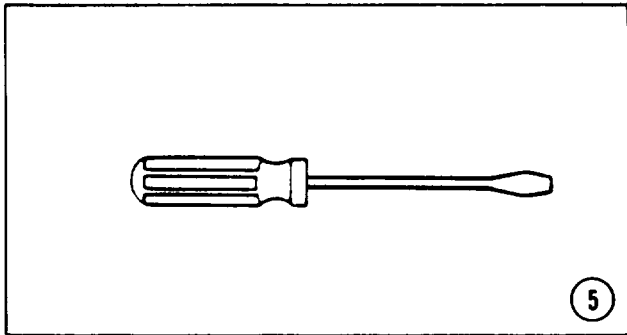
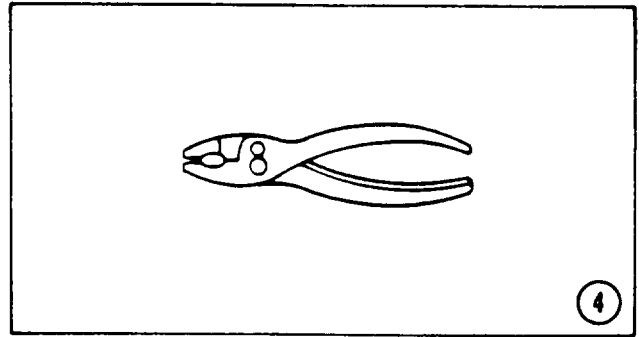
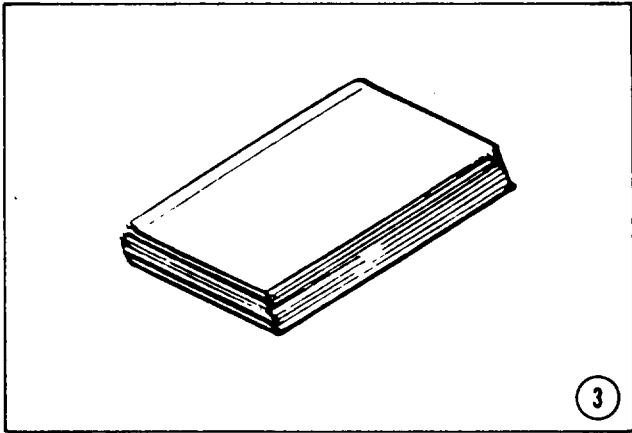

(1) ILLUS NUMBER	(2) NATIONAL STOCK NUMBER	(3) DESCRIPTION CAGE AND PART NUMBER	(4) U/M	(5) QTY REQD
3		MANUAL, TECHNICAL TM5-4610-233-13&P	EA	1
4		PLIERS, SLIP JOINT, 6-INCH (71229)D-249688	EA	1
5		SCREWDRIVER, FLAT TIP, 3/16 X 4 INCHES (71229)D-249686	EA	1
6		WRENCH, ADJUSTABLE, 8-INCH (71229)D-249687	EA	1

APPENDIX D

ADDITIONAL AUTHORIZATION LIST

Not Applicable

Appendix E. EXPENDABLE/DURABLE SUPPLIES AND MATERIALS LIST

Section I. INTRODUCTION

E-1. SCOPE.

This appendix lists expendable/durable supplies and materials list that you will need to operate and maintain the Water Purification Hypochlorination Unit. This listing is for information only and is not authority to requisition the listed items. These items are authorized to you by CTA 50-790, Expendable/Durable Items (except medical, class V repair parts, and heraldic items), or CTA8-100, Army Medical Department Expendable/Durable Items.

E-2. EXPLANATION OF COLUMNS.

a. Column 1. Item number. This number is assigned to the entry in the listing and is referenced in the narrative instructions to identify the item (e.g. "Use cleaning compound, item 4, Appendix E".)

b. Column 2. Level. This column identifies the lowest level of maintenance that requires the item.

- C - Operator/crew
- O- Unit maintenance
- F - Direct support maintenance
- H - General support maintenance
- D - Depot

c. Column 3. National stock number. This is the national stock number assigned to the item which you can use to requisition it.

d. Column 4. Item name, description, Commercial and Government Entity Code (CAGEC), and part number. This provides the other information you need to identify the item.

e. Column 5. Unit of measure. This code shows the physical measurement or count of an item, such as gallon, dozen, gross, etc,

SECTION II. EXPENDABLE/DURABLE SUPPLIES AND MATERIALS LIST

(1) ITEM NO.	(2) LEVEL	(3) NATIONAL STOCK NUMBER	(4) DESCRIPTION	(5) U/M
1	C	6810-00-242-4770	CALCIUM HYPOCHLORITE (81348)0C114	
2	C	6810-01-044-0315	REAGENT DPD-1 (12308)U-25410	
3	C	6630-01-044-0334	REAGENT PH COLOR INDICATOR (12308)U25337	
4	O	8030-00-889-3535	TAPE, ANTISEIZE (81349)MIL-T-27730	
5			DELETED	

APPENDIX F

OPERATOR, UNIT AND DIRECT SUPPORT
MAINTENANCE
REPAIR PARTS AND SPECIAL TOOLS LIST

SECTION I. INTRODUCTION

1. SCOPE. This RPSTL lists and authorizes spares and repair parts; special tools; special test, measurement, and diagnostic equipment (TMDE); and other special support equipment required for performance of operator, unit and direct support maintenance of the Hypochlorination Unit. It authorizes the requisitioning, issue, and disposition of spares, repair parts and special tools as indicated by the source, maintenance and recoverability (SMR) codes.

2. GENERAL. In addition to this section, Introduction, this Repair Parts and Special Tools List is divided into the following sections:

a. Section II. Repair Parts List. A list of spares and repair parts authorized by this RPSTL for use in the performance of maintenance. The list also includes parts which must be removed for replacement of the authorized parts. Paris lists are composed of functional groups in ascending alphanumeric sequence, with the parts in each group listed in ascending figure and item number sequence. Bulk materials are listed in item name sequence. Repair parts kits are listed separately in their own functional group within Section II. Repair parts for repairable special tools are also listed in this section. Items listed are shown on the associated illustration (s)/figure(s).

b. Section III. Special Tools List. A list of special tools, special TM DE, and other special support equipment authorized by this RPSTL (as indicated by Basis of Issue (BOI) information in DESCRIPTION AND USABLE ON CODE column) for the performance of maintenance.

c. Section IV. Cross-references Indexes. A list, in National Item Identification Number (NIIN) sequence, of all National stock numbered items appearing in the listing, followed by a list in alphanumeric sequence of all part numbers appearing in the listings, National stock numbers and part numbers are cross referenced to each illustration figure and item number appearance. The figure and item number index lists figure and item number in alphanumeric sequence and cross references NSN, FSCM and part number,

3. EXPLANATION OF COLUMNS (SECTIONS II AND III).

a. ITEM NO. (Column (1)). indicates the number used to identify items called out in the illustration,

b. SMR Code (Column (2)). The Source, Maintenance, and Recoverability (SMR) code is a 5-position code containing supply/requisitioning information, maintenance category authorization criteria, and disposition instruction, as shown in the following breakout:

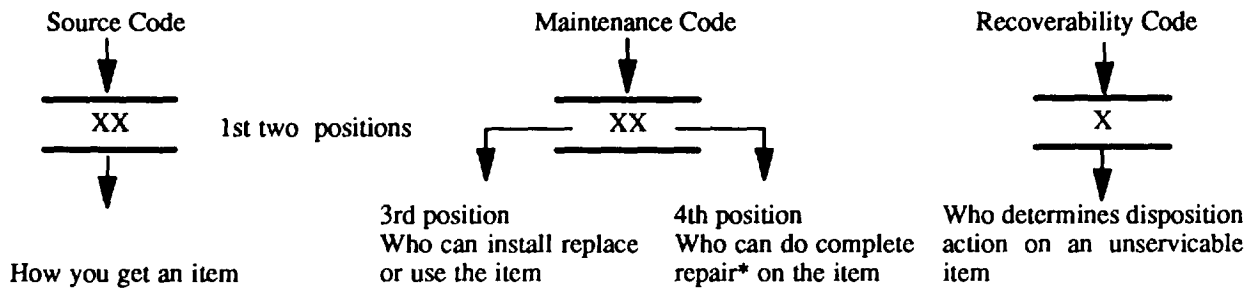

NOTE

* Complete Repair: Maintenance capacity, capability, and authority to perform all corrective maintenance tasks of the "Repair" function in a use/user environment in order to restore serviceability to a failed item.

(1) Source Code. The source code tells you how to get an item needed for maintenance, repair, or overhaul of an end item/equipment. Explanations of source codes follows:

Code	Explanation
PA PB PC**	Stocked items: use the applicable NSN to request/requisition items with these source codes. "They are authorized to the category indicated by the code entered in the 3d position of the SMR code.
PD PE PF PG	
KD KF KB	* **NOTE: Items coded PC are subject to deterioration.
	Items with these codes are not to be requested/requisitioned individually. They are part of a kit which is authorized to the maintenance category indicated in the 3d position of the SMR code. The complete kit must be requisitioned and applied.

	Explanation
MO— (Made at org AVUM Level)	Items with these codes are not to be requested/requisitioned individually. They must be made from bulk material which is identified by the part number in the DESCRIPTION and USABLE ON CODE (UOC) column and listed in the Bulk Material group of the repair parts list in this RPSTL. If the item is authorized to you by the 3d position code of the SMR code, but the source code indicates it is made at a higher level, order the item from the higher level of maintenance.
MF — (Made at DS/AVUM Level)	
MH — (Made at GS Level)	
ML — (Made at Specialized Repair Activity (SRA))	
MD — (Made at Depot)	

	Explanation
AO — (Assembled by org/AVUM Level)	Items with these codes are not to be requested/requisitioned individually. The parts that make up the assembled item must be requisitioned or fabricated and assembled at the level of maintenance indicated by the source code. If the 3d position code of the SMR code authorizes you to replace the item, but the source code indicates the items are assembled at a higher level, order the item from the higher level of maintenance.
AF — Assembled by DS/AVIM Level	
AH — (Assembled by GS Category)	
AL — (Assembled by SRA)	
AD — (Assembled by Depot)	

Code	Explanation
XA	--Do not requisition "XA"-coded item. Order its next higher assembly. (Also, refer to the NOTE below.)
XB	- - If an "XB" item is not available from salvage, order it using the FSCM and part number given,
XC	-- Installation drawing, diagram, instruction sheet, field service drawing, that is identified by Reciprocating Compressor manufacturer's part number.
XD	-- Item is not stocked. Order an "XD"-coded item through normal supply channels using the FSCM and part number given, if no NSN is available.

NOTE

Cannibalization or controlled exchange, when authorized, may be used as a source of supply for items with the above source codes, except for those source coded 'XA' or those aircraft support items restricted by requirements of AR 750-1.

(2) Maintenance Code. Maintenance codes tells you the level(s) of maintenance authorized to USE and REPAIR support items. The maintenance codes are entered in the third and fourth positions of the SMR code as follows:

(a) The maintenance code entered in the third position tells you the lowest maintenance level authorized to remove, replace, and use an item. The maintenance code entered in the third position will indicate authorization to one of the following levels of maintenance.

Code	Application/Explanation
C	— Crew or operator maintenance done within organizational or aviation unit maintenance.
O	— Organizational or aviation unit category can remove, replace, and use the item.
F	— Direct support or aviation intermediate level can remove, replace, and use the item.
H	— General support level can remove, replace, and use the item.
L	— Specialized repair activity can remove, replace, and use the item.
D	— Depot level can remove, replace, and use the item.

(b) The maintenance code entered in the fourth position tells whether or not the item is to be repaired and identifies the lowest maintenance level with the capability to do complete repair (i.e., perform all authorized repair functions.) NOTE: Some limited repair may be done on the item at a lower level of maintenance, if authorized by the Maintenance Allocation Chart (MAC) and SMR codes. This position will contain one of the following maintenance codes.

Code	Application/Explanation
O	— Organizational or (aviation unit) is the lowest level that can do complete repair of the item.
F	— Direct support or aviation intermediate is the lowest level that can do complete repair of the item.
H	— General Support is the lowest level that can do complete repair of the item.
L	— Specialized repair activity is the lowest level that can do complete repair of the item.
D	— Depot is the lowest level that can do complete repair of the item.
Z	— Nonreparable. No repair is authorized.
B	— No repair is authorized. (No parts or special tools are authorized for the maintenance of a "B" coded item) However, the item may be reconditioned by adjusting, lubricating, etc., at the user level.

(3) Recoverability Code. Recoverability codes are assigned to items to indicate the disposition action on unserviceable items. The recoverability code is entered in the fifth position of the SMR Code as follows:

Recoverability Codes	Application/Explanation
Z	— Nonreparable item. When unserviceable, condemn and dispose of the item at the level of maintenance shown in 3d position of SMR Code.
O	— Repairable item. When uneconomically repairable, condemn and dispose of the item at organizational or aviation unit level
F	— Repairable item. When uneconomically repairable, condemn and dispose of the item at the direct support or aviation intermediate level
H	— Repairable item. When uneconomically repairable, condemn and dispose of the item at the general support level.
D	— Repairable item. When beyond lower level repair capability, return to depot. Condemnation and disposal of item not authorized below depot level.
L	— Repairable item. Condemnation and disposal not authorized below specialized repair activity (SRA).
A	— Item requires special handling or condemnation procedures because of specific reasons (e.g., precious metal content, high dollar value, critical material, or hazardous material). Refer to appropriate manuals/directives for specific instructions.

c. FSCM (Column (3)). The Federal Supply Code for Manufacturer (FSCM) is a 5-digit numeric code which is used to identify the manufacturer, distributor, or Government agency, etc., that supplies the item.

d. PART NUMBER (Column (4)). Indicates the primary number used by the manufacturer, (individual, company, firm, corporation, or Government activity), which controls the design and characteristics of the item by means of its engineering drawings, specifications standards, and inspection requirements to identify an item or range of items.

NOTE

When you use an NSN to requisition an item, the item you receive may have a different part number from the part ordered.

e. DESCRIPTION AND USABLE ON CODE (UOC) (Column (5)). This column includes the following information:

- (1) The Federal item name and, when required, a minimum description to identify the item.
- (2) The physical security classification of the item is indicated by the parenthetical entry, e.g., Phy Sec CI - Confidential, Phy Sec CI (S) - Secret, Phy Sec CI (T) - Top Secret.
- (3) Items that are included in kits and sets are listed below the name of the kit or set.
- (4) Spare/repair parts that make up an assembled item are listed immediately following the assembled item line entry.
- (5) Part numbers for bulk materials are referenced in this column in the line item entry for the item to be manufactured/fabricated.
- (6) When the item is not used with all serial numbers of the same model, the effective serial numbers are shown on the last line(s) of the description (before UOC).
- (7) The usable on code, when applicable (see paragraph 5, Special Information).
- (8) In the Special Tools List section, the basis of issue (BOI) appears as the last line(s) in the entry for each special tool, special TM DE, and other special support equipment. When density of equipments supported exceeds density spread indicated in the basis of issue, the total authorization is increased proportionately.
- (9) The statement "END OF FIGURE" appears just below the last item description in Column 5 for a given figure in both Section II and Section III.
- (10) The indenture, shown as dots appearing before the repair part, indicates that the item is a repair part of the next higher assembly.

f. QTY (Column (6)). The QTY (quantity per figure column) indicates the quantity of the item used in the breakout shown on the illustration figure, which is prepared for a functional group, subfunctional group, or an assembly. A "V" appearing in this column in lieu of a quantity indicates that the quantity is variable and may vary from application to application.

4. EXPLANATION OF COLUMNS (SECTION IV).

a. NATIONAL STOCK NUMBER (NSN) INDEX.

(1) STOCK NUMBER column. This column lists the NSN by National item identification number (NIIN) sequence. The NIIN consists of the last nine digits of the NSN i.e. (5305-01-574-1467). NIIN

When using this column to locate an item, ignore the first 4 digits of the NSN. However, the complete NSN should be used when ordering items by stock number.

(2) FIG. column. This column lists the number of the figure where the item is identified/located. The figures are in numerical order in Section II and Section III.

(3) ITEM column. The item number identifies the item associated with the figure listed in the adjacent FIG. column. This item is also identified by the NSN listed on the same line.

b. PART NUMBER INDEX. Part numbers in this index are listed by part number in ascending alphanumeric sequence (i e. , vertical arrangement of letter and number combination which places the first letter or digit of each group in order A through Z, followed by the numbers 0 through 9 and each following letter or digit in like order).

(1) FSCM column. The Federal Supply Code for Manufacturer (FSCM) is a 5-digit numeric code used to identify the manufacturer, distributor, or Government agency, etc., that supplies the item.

(2) PART NUMBER column. Indicates the primary number used by the manufacturer (individual, firm, corporation, or Government activity), which controls the design and characteristics of the item by means of its engineering drawings, specifications standards, and inspection requirements to identify an item or range of items.

(3) STOCK NUMBER column. This column lists the NSN for the associated part number and manufacturer identified in the PART NUMBER and FSCM columns to the left.

(4) FIG. column. This column lists the number of the figure where the item is identified/located in Sections II and III.

(5) ITEM column. The item number is that number assigned to the item as it appears in the figure referenced in adjacent figure number column.

c. FIGURE AND ITEM NUMBER INDEX.

(1) FIG. column. This column lists the number of the figure where the item is identified/located in Section II and III.

(2) ITEM column. The item number is that number assigned to the item as it appears in the figure referenced in the adjacent figure number column.

(3) STOCK NUMBER column. This column lists the NSN for the item.

(4) FSCM column. The Federal Supply Code for Manufacturer (FSCM) is a 5-digit numeric code used to identify the manufacturer, distributor, or Government agency, etc., that supplies the item.

(5) PART NUMBER column. Indicates the primary number used by the manufacturer (individual, firm, corporation, or Government activity), which controls the design and characteristics of the item by means of its engineering drawings, specifications standards, and inspection requirements to identify an item or range of items,

5. SPECIAL INFORMATION.

a. USABLE ON CODE. The usable on code appears in the lower corner of the Description column heading. Usable on codes are shown as "UOC:" in the Description Column (justified left) on the last line applicable item description/nomenclature. Uncoded items are applicable to all models.

b. ASSOCIATED PUBLICATIONS. Not Applicable.

6. HOW TO LOCATE REPAIR PARTS.

a. When National Stock Number or Part Number is NOT known.

(1) First. Using the table of contents, determine the assembly group or subassembly group to which the item belongs. This is necessary since figures are prepared for assembly groups and subassembly groups, and listings are divided into the same groups.

(2) Second. Find the figure covering the assembly group or subassembly group to which the item belongs.

(3) Third. Identify the item on the figure and note the item number.

(4) Fourth. Refer to the Repair Parts List for the figure to find the part number for the item number noted on the figure.

(5) Fifth. Refer to the Part Number Index to find the NSN, if assigned.

b. When National Stock Number or Part Number is Known:

(1) First. Using the Index of National Stock Numbers and Part Numbers, find the pertinent National Stock Number or Part Number. The NSN index is in National Item Identification Number (NIIN) sequence (see c-4a.(1)). The part numbers in the Part Number index are listed in ascending alphanumeric sequence (see paragraph c-4.b). Both indexes cross-reference you to the illustration figure and item number of the item you are looking for.

(2) Second. After finding the figure and item number, verify that the item is the one you are looking for, then locate the item number in the repair parts list for the figure.

7. ABBREVIATIONS.

Abbreviations used in this manual are listed in MIL-STD-12.

Section II. REPAIR PARTS LIST

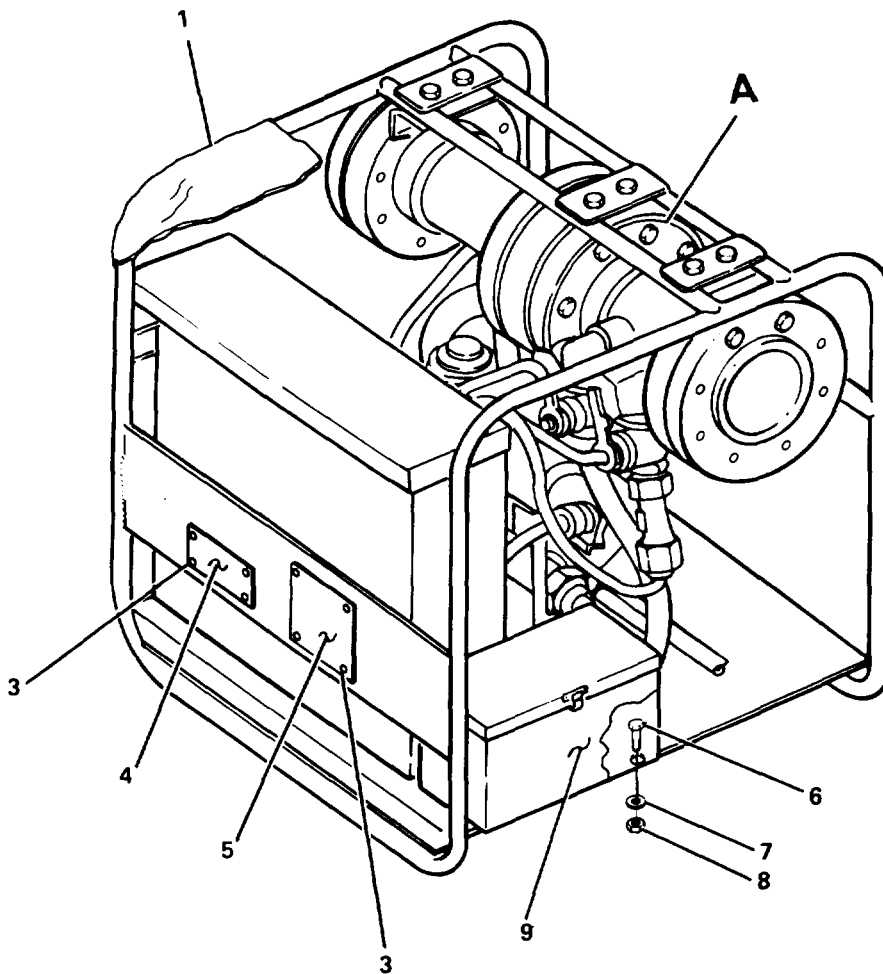

ITEM 2 NOT ILLUSTRATED

41043-206

Figure F-1. Frame-Mounted Water Purification Hypochlorination Unit
(Sheet 1 of 5)

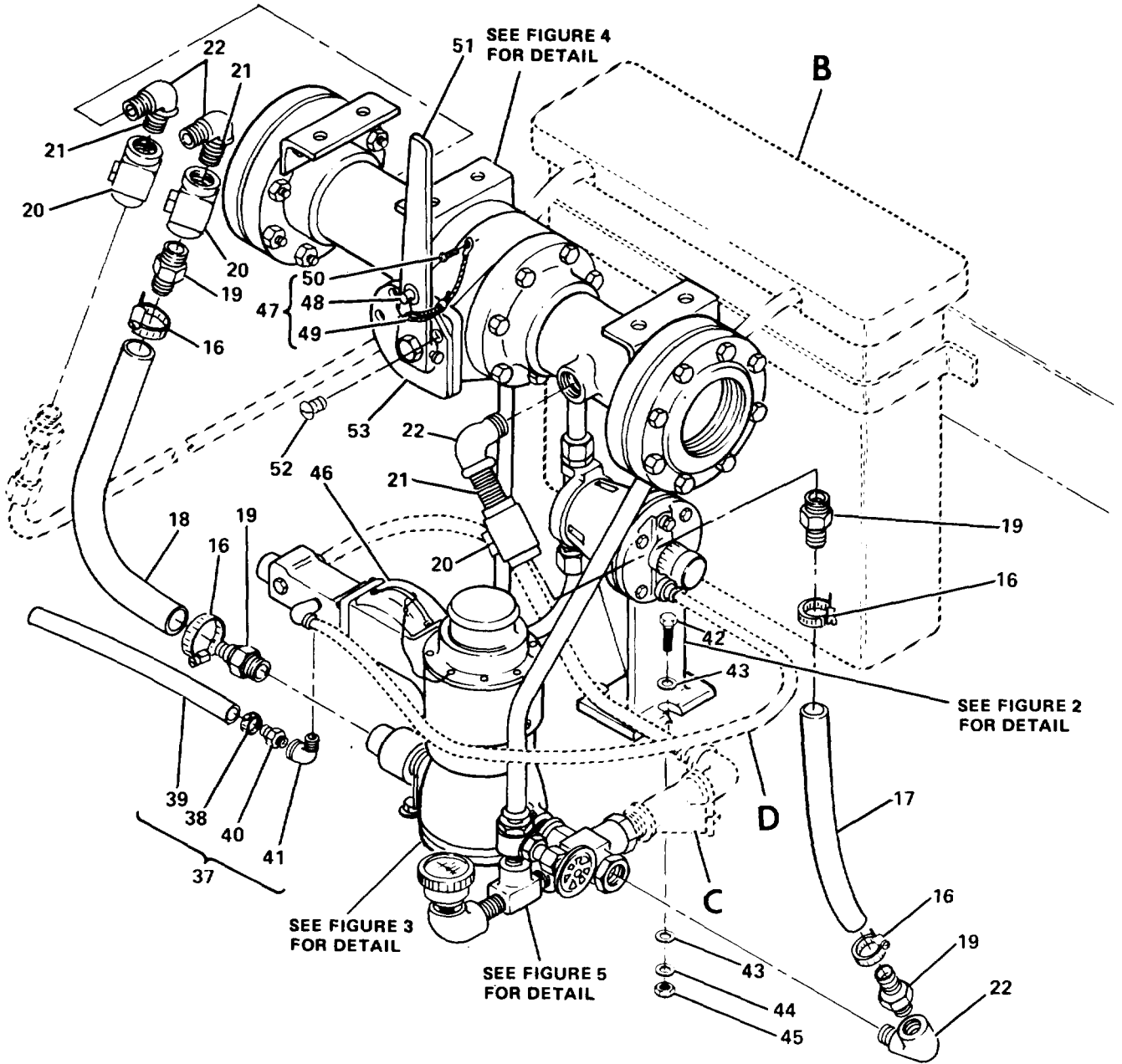

ROTATED 180°

A

41043-207

Figure F-1. Frame-Mounted Water Purification Hypochlorination Unit
(Sheet 2 of 5)

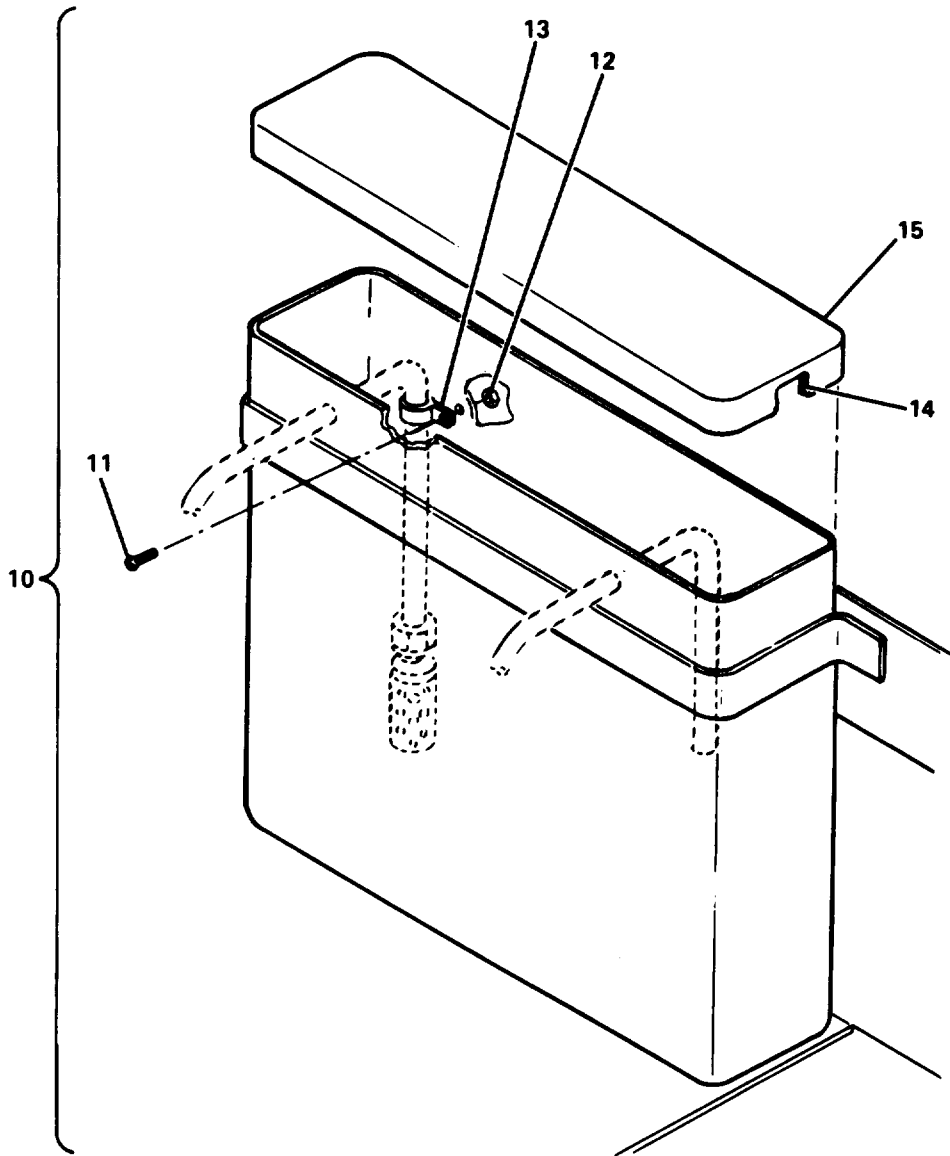

B

41043-208

Figure F-1. Frame-Mounted Water Purification Hypochlorination Unit
(sheet 3 of 5)

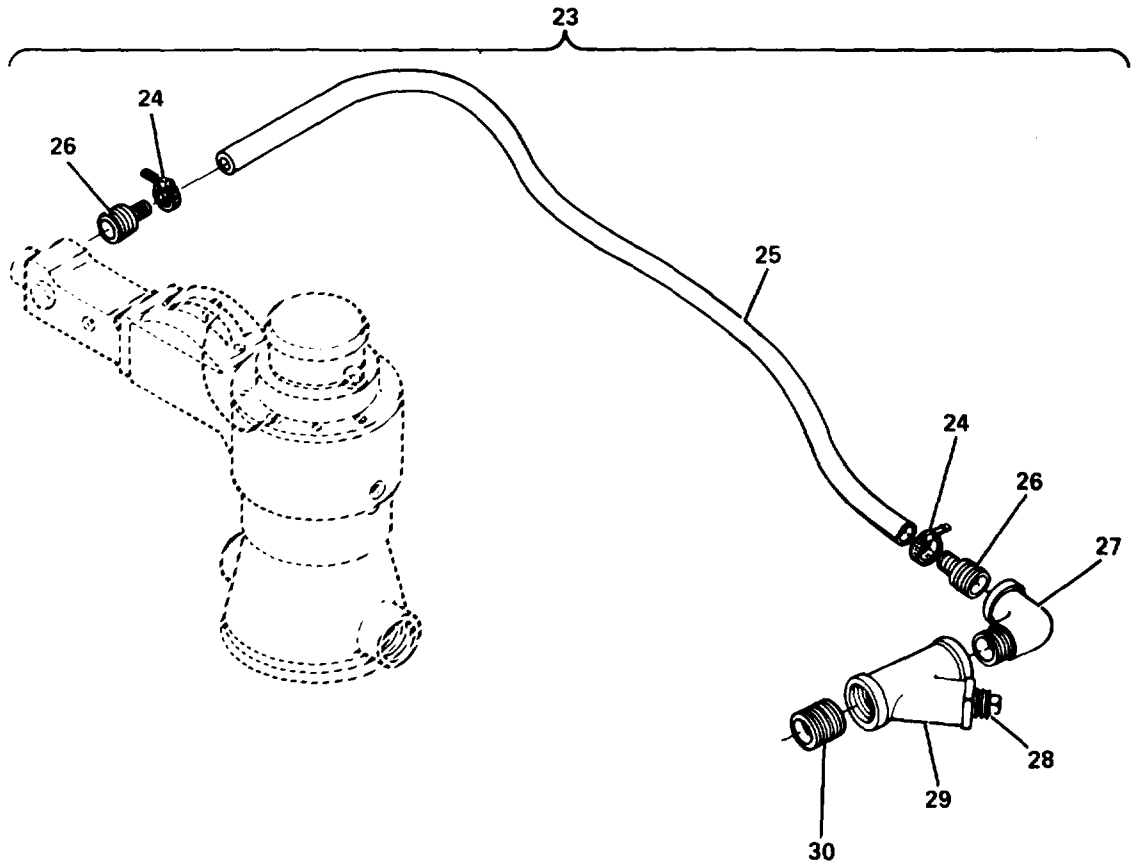

C

41043-209

Figure F-1. Frame-Mounted Water Purification Hypochlorination Unit
(Sheet 4 of 5)

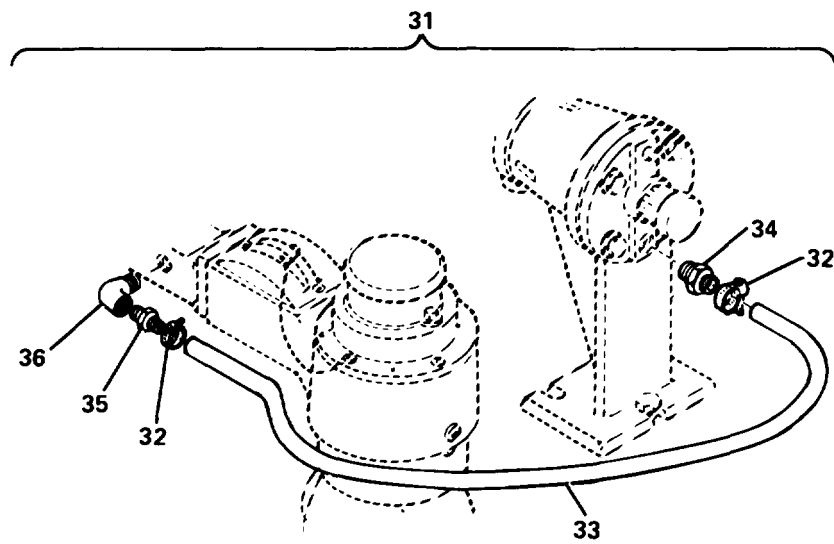

D

41043-210

Figure F-1. Frame-Mounted Water Purification Hypochlorination Unit
(Sheet 5 of 5)

(1) ITEM NO	(2) SMR CODE	(3) FSCM	(4) PART NUMBER	(5) DESCRIPTION AND USABLE ON CODE (UOC)	(6) QTY
GROUP 00 HYPOCHLORINATION UNIT, WATER PURIFICATION					
FIG. F-1 FRAME-MOUNTED WATER PURIFICATION HYPOCHLORINATION UNIT					
1	XDOZZ	71229	245249	COVER,CANVAS	1
2	MOOZZ	71229	260028	.ROPE NOT ILLUSTRATED	1
3	PAOZZ	71229	4170063678	SCREW,MACH.6-32	8
4	XDOZZ	71229	249666	NAMEPLATE	1
5	XDOZZ	71229	249665	PLATE,INSTRUCTION	1
6	PAOZZ	71229	4170063741	SCREW,MACH	2
7	PAOZZ	71229	4170036322	WASHER,LOCK	2
8	PAOZZ	71229	4170022025	NUT, 1/4-20	2
9	PAOZZ	71229	249683-3	TOOL BOX AND TOOL SET	1
10	PAOOF	71229	249678	TANK ASSY,RESERVOIR PART OF KIT P/N 249680	1
11	PAOZZ	71229	4170063663	.SCREW,PAN HD,5-40 5-40 UNCX1/2IN. LG,SST	1
12	PAOZZ	71229	4170023042	.NUT, NO. 5-40 UNC, ST	1
13	PAOZZ	71229	180287-3	.CLAMP	1
14	MOOZZ	71229	182177-2	.STRIPPING,FOAM M/F P/N 4763(82094) 1/2W X 1/4T,GRAY POLYURETHANE FOAM	V
15	PAOFF	71229	245213	.TANK AND COVER	1
16	PAOZZ	71229	251293-2	CLAMP PART OF KIT P/N 249680	4
17	PAOZZ	71229	251024-2	HOSE INLET	1
18	PAOZZ	71229	251024-3	HOSE,OUTLET	1
19	XDOZZ	71229	191475-6	FITTING,HOSE	4
20	PAOZZ	71229	239493	COCK,SHUT-OFF, 3/4 IN	3
21	PAOZZ	71229	416-3309-046	NIPPLE,SHORT, 3/4 IN	3
22	PAOZZ	71229	416-3308-005	ELBOW,STREET, 3/4 IN	4
23	PAOOF	71229	239384	HOSE ASSY,INLET	1
24	PAOZZ	81646	6806	.CLAMP PART OF KIT P/N 249680	2
25	XDOZZ	71229	239386-6	.TUBE,T-O-C INLET, 20 IN LG	1
26	PAOZZ	71229	814399	.CONNECTION,HOSE	2
27	PAOZZ	71229	416-3308-004	.ELBOW,STREET	1
28	PAOZZ	71229	416-3310-002	.PLUG,SQUARE HEAD, 1/4 IN. NPT	1
29	XDOZZ	71229	249690	.STRAINER,Y, 1/2 IN. NPT	1
30	PAOZZ	71229	416-3309-034	.NIPPLE,CLOSE, 1/2 IN. NPT	1
31	PAOOF	71229	239381	HOSE ASSY,OUTLET	1
32	PAOZZ	81646	6806	.CLAMP	2
33	XDOZZ	71229	239386-3	.TUBE,T-O-C OUTLET, 32 IN. LG	1
34	PAOZZ	71229	814402	.CONNECTION,HOSE	1
35	PAOZZ	71229	814398	.CONNECTION,HOSE	1
36	PAOZZ	71229	416-3308-003	.ELBOW,STREET, 3/8 IN. NPT	1
37	PAOOF	71229	239382	HOSE ASSY,DRAIN	1
38	PAOZZ	71229	251293-2	.CLAMP PART OF KIT P/N 249680	1
39	XDOZZ	71229	251024-1	.HOSE,DRAIN	1
40	PAOZZ	71229	814400	.CONNECTION,HOSE	1
41	PAOZZ	71229	416-3308-004	.ELBOW,STREET, 1/2 IN	1

(1) ITEM NO	(2) SMR CODE	(3) FSCM	(4) PART NUMBER	(5) DESCRIPTION AND USABLE ON CODE (UOC)	(6) QTY
42	PAOZZ	71229	4170052126	BOLT, 5/16-18X 1 1/4 IN	3
43	PAOZZ	71229	4170037056	WASHER,FLAT 5/16 IN	6
44	PAOZZ	71229	4170037024	WASHER,LOCK	3
45	PAOZZ	71229	4170022026	NUT, 5/16-18	3
46	XDOZZ	71229	245128	COVER WITH HOLDING CABLE,FLOW CONTROLLER	1
47	XDOZZ	71229	249679	LOCKING PIN AND CABLE ASSY	1
48	PAOZZ	71229	249670	.PIN	1
49	XDOZZ	71229	249671	.CABLE	1
50	PAOZZ	71229	417-0075-718	.SCREW,SELF-TAPPING, NO.10-32UNC X 3/8IN. LG	1
51	XDOZZ	71229	249673	HANDLE,LEVER OPERATING	1
52	PAOZZ	71229	260029	SCREW,HEX SOCKET HD 5/16-18 U	2
53	XDOZZ	71229	249672	PLATE,STOP	1

END OF FIGURE

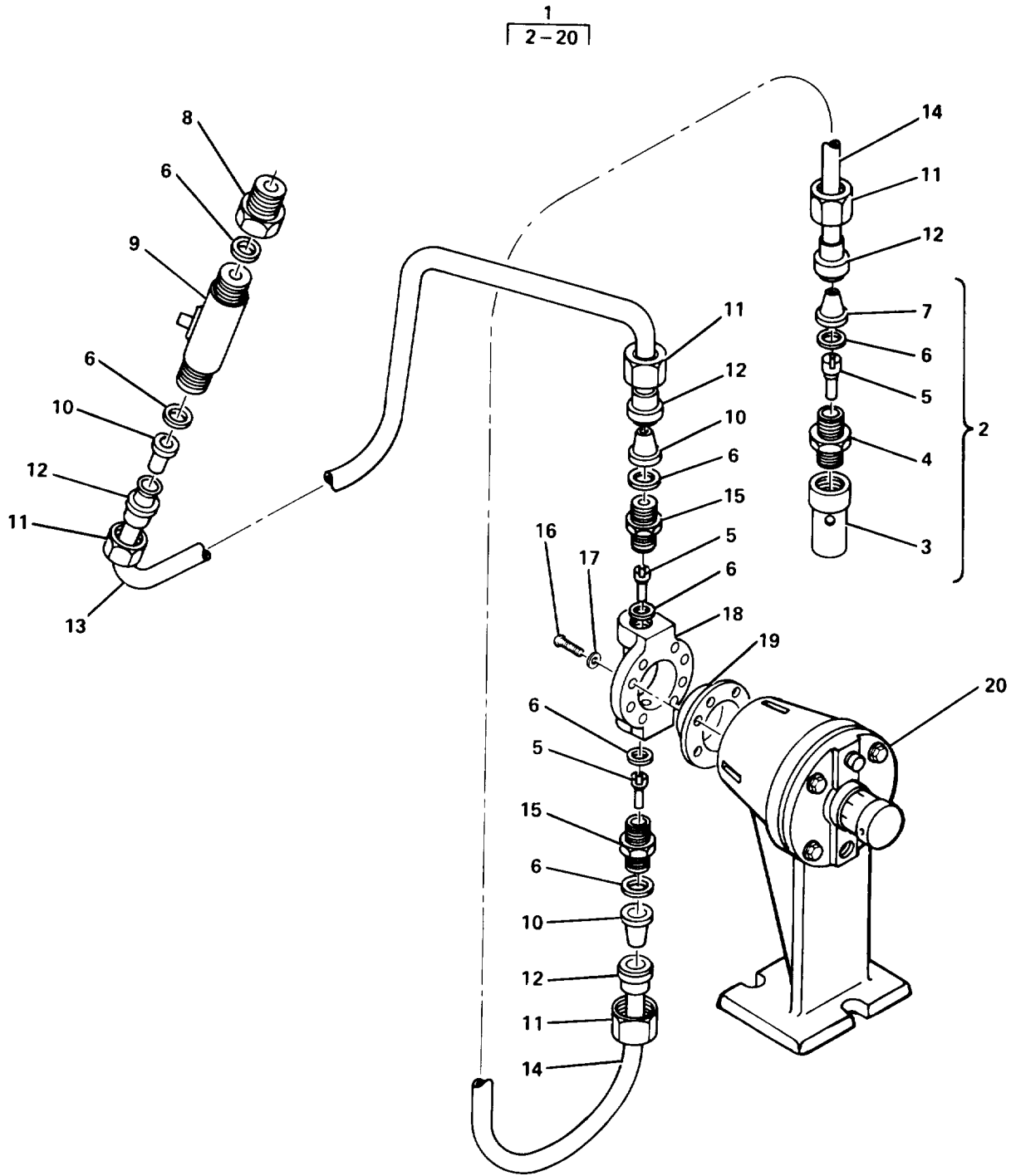

41043-211

Figure F-2. Solution Feed Pump

(1) ITEM NO	(2) SMR CODE	(3) FSCM	(4) PART NUMBER	(5) DESCRIPTION AND USABLE ON CODE (UOC)	(6) QTY
GROUP 01 SOLUTION FEED PUMP, MODEL 1261					
FIG. F-2 SOLUTION FEED PUMP					
1	PAOOF	71229	249674-1	PUMP,SOLUTION FEED	1
2	PAOOF	71229	807305-2	.VALVE ASSY,FOOT	1
3	XDOZZ	71229	G-855	..CUP,STRAINER	1
4	XDOZZ	71229	G-1197-3	..BODY,CHECK VALVE	1
5	PAOZZ	71229	806515-3	..VALVE,CHECK PART OF KIT P/N 249680	3
6	PAOZZ	71229	812699-1	..WASHER,CHECK VALVE PART OF KIT P/N 249680	7
7	PAOZZ	71229	G-854	..NIPPLE,FLARING PART OF KIT P/N 249680	1
8	PAOZZ	71229	249127	.HEAD,NOZZLE, INJECTION	1
9	PAOZZ	71229	806365-4	.VALVE,ANTI-SYPHON	1
10	PAOZZ	71229	G-854	.NIPPLE,FLARING PART OF KIT P/N 249680	3
11	PAOZZ	71229	F-921-1	.NUT,TUBE PART OF KIT P/N 249680	4
12	PAOZZ	71229	F920-BK	.FERRULE,TUBE PART OF KIT P/N 249680	4
13	MOOZZ	71229	239386-4	.TUBE,PUMP DISCHARGE MADE FROM P/N 811805-2	1
14	MOOZZ	71229	239386-1	.TUBE,PUMP SUCTION MADE FROM P/N 811805-2	1
15	XDOZZ	71229	G-1197-3	.BODY,CHECK VALVE	2
16	PAOZZ	71229	4170061724	.SCREW,MACHINE, PHILLIPS HD, NO.10-32UNC X 1IN. LG	8
17	PAOZZ	71229	F-11	.WASHER	8
18	PAOZZ	71229	805285-2	.HEAD,LIQUID	1
19	PAOZZ	71229	0F726-V	.DIAPHRAM PART OF KIT P/N 249680	1
20	PAOZZ	71229	460179	.PUMP,FRAME ASSY	1

END OF FIGURE

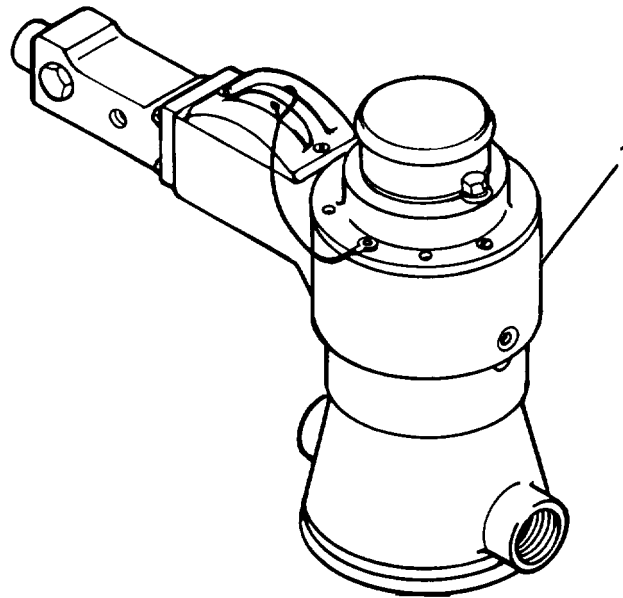

41043-212

Figure F-3. Flow Controller with Meter Adapter Parts

(1) ITEM NO	(2) SMR CODE	(3) FSCM	(4) PART NUMBER	(5) DESCRIPTION AND USABLE ON CODE (UOC)	(6) QTY
				GROUP 02 FLOW CONTROLLER	
				FIG. F-3 FLOW CONTROLLER WITH METER ADAPTER PARTS	
1	PAODD	71229	249676	CONTROLLER, FLOW WITH METER ADAPTER PARTS	1
				END OF FIGURE	

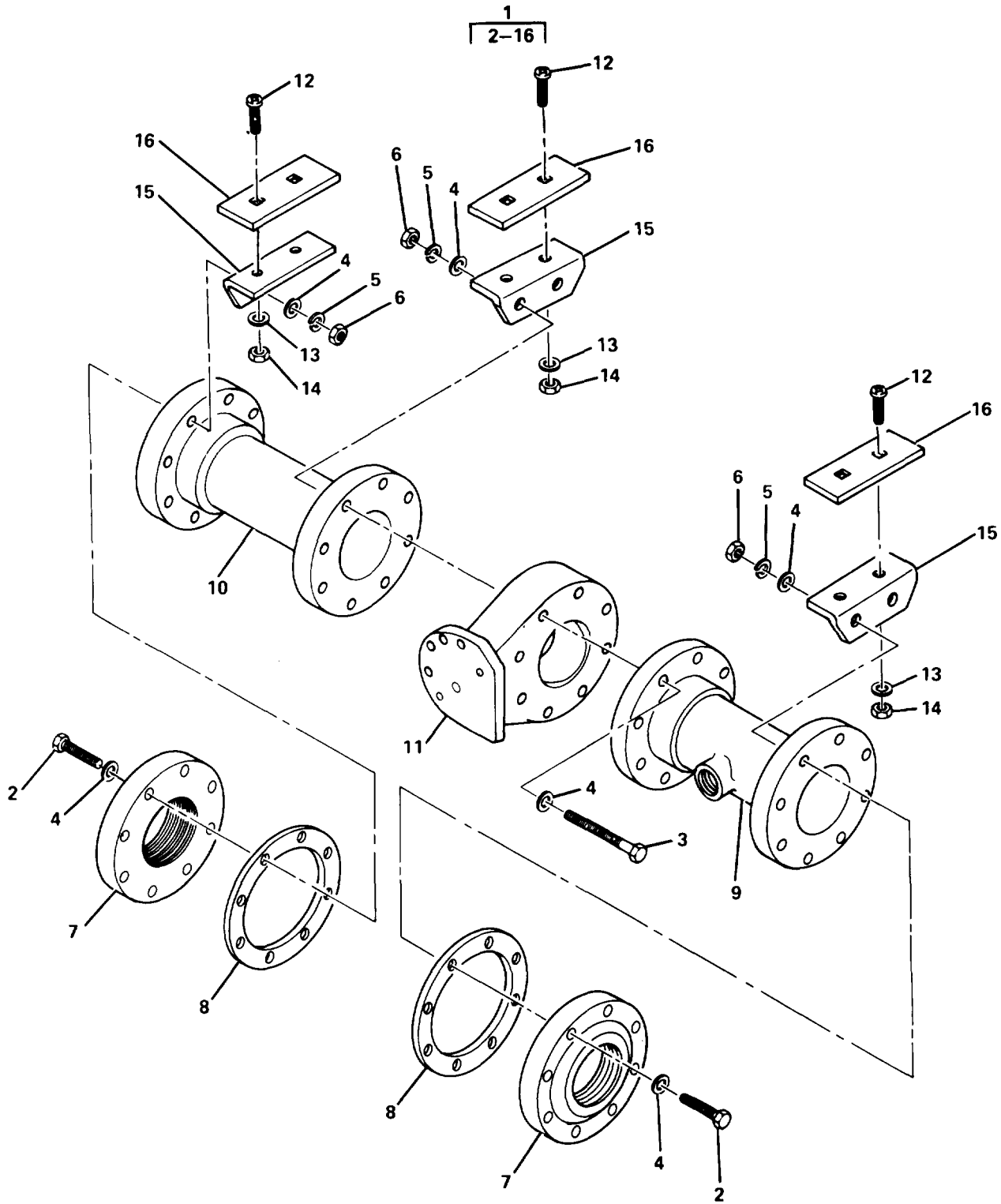

41043-213

Figure F-4. 4-Inch Manifold Assembly

(1) ITEM NO	(2) SMR CODE	(3) FSCM	(4) PART NUMBER	(5) DESCRIPTION AND USABLE ON CODE (UOC)	(6) QTY
GROUP 03 MANIFOLD ASSEMBLY 4-INCH					
FIG. F-4 4-INCH MANIFOLD ASSEMBLY					
1	PAOOF	71229	249682	MANIFOLD ASSY, 4 IN	1
2	PAOZZ	71229	4170052176	.BOLT, HEX HEAD	16
3	PAOZZ	71229	4170052492	.BOLT, HEX HEAD	8
4	PAOZZ	71229	4170037059	.WASHER, 5/8 IN	48
5	PAOZZ	71229	4170036027	.LOCKWASHER	24
6	PAOZZ	71229	4170022029	.NUT, HEX	24
7	XDOZZ	71229	251294	.FLANGE, 4 IN	2
8	PAOZZ	71229	181440-233	.GASKET CAMPANION	2
9	XDOZZ	71229	239483	.SPOOL, INLET PIPE	1
10	XDOZZ	71229	239484	.SPOOL, OUTLET PIPE	1
11	PAOOF	71229	260003	.VALVE, 4 IN. BUTTERFLY, RANGE ADJUSTING	1
12	XDOZZ	71229	4170011063	.CARRIAGE	6
13	PAOZZ	71229	4170036025	.LOCKWASHER	6
14	PAOZZ	71229	4170022027	.NUT, HEX FULL 3/8-16	6
15	XDOZZ	71229	239485	.BRACKET, SUPPORT, MANIFOLD	3
16	PAOZZ	71229	239486	.CLAMP, BRACKET	3

END OF FIGURE

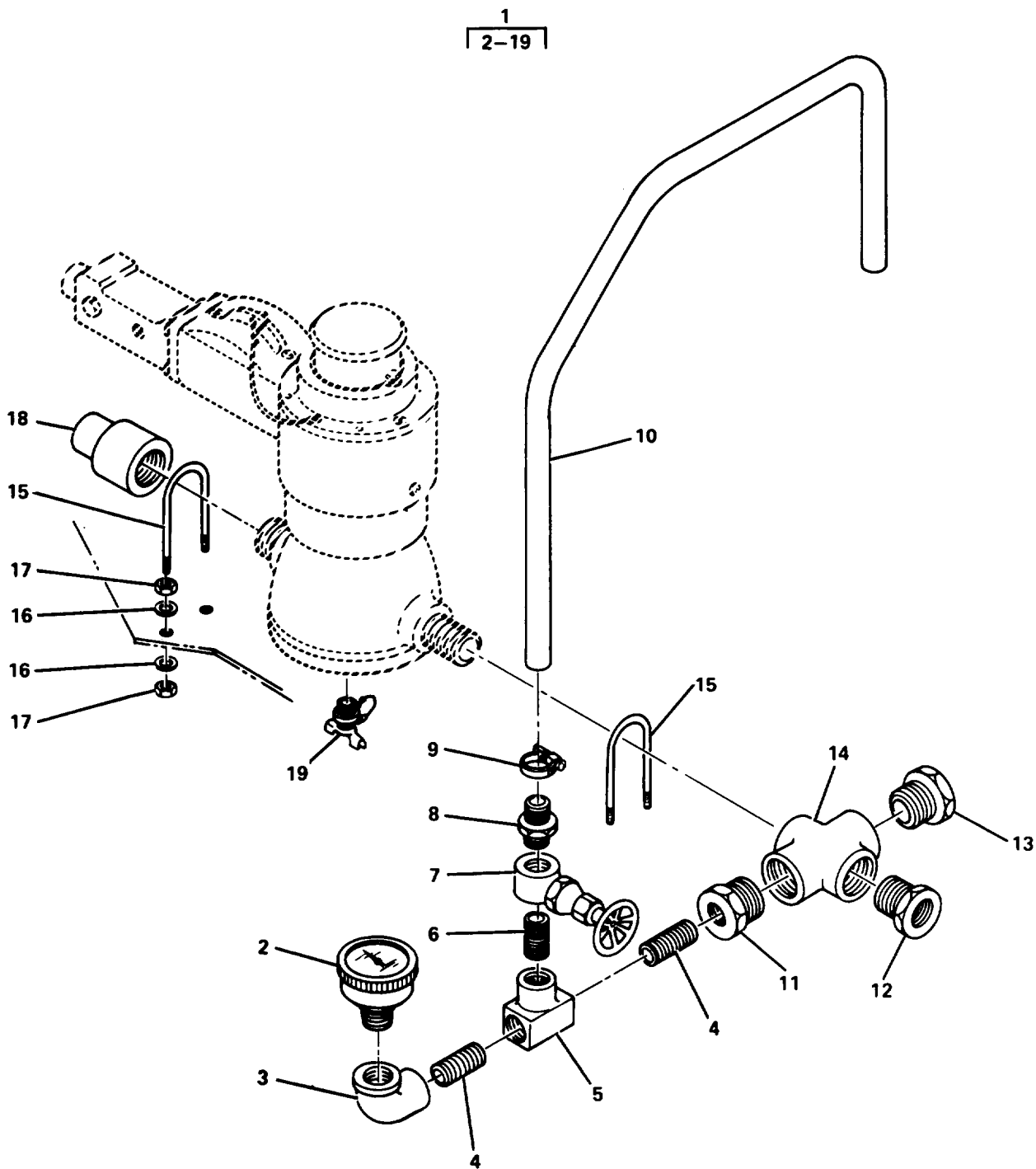

41043-214

Figure F-5. Manifold Assembly With Pressure Gage, Globe Valve, and Fill Hose

(1) ITEM NO	(2) SMR CODE	(3) FSCM	(4) PART NUMBER	(5) DESCRIPTION AND USABLE ON CODE (UOC)	(6) QTY
				GROUP 04 MANIFOLD ASSEMBLY WITH PRESSURE GAGE, GLOBE VALVE, AND FILL HOSE	
				FIG. F-5 MANIFOLD ASSEMBLY WITH PRESSURE GAGE, GLOBE VALVE, AND FILL HOSE	
1	PAOOF	71229	249667	MANIFOLD ASSY WITH PRESSURE GAGE, GLOBE VALVE AND FILL HOSE	1
2	PAOZZ	71229	434-0102-004	.GAUGE,PRESSURE, 0-100 PSI	1
3	PAOZZ	71229	416-3307-002	.ELBOW,1/4 IN.BRASS	1
4	PAOZZ	71229	416-3309-013	.NIPPLE,BRASS 1/4 IN	2
5	PAOZZ	71229	416-3311-002	.TEE, 1/4 IN. BRASS	1
6	PAOZZ	71229	416-3309-012	.NIPPLE, 1/4 IN. BRASS	1
7	PAOZZ	71229	439-0101-002	.VALVE,GLOBE, 1/4 IN. BRASS	1
8	PAOZZ	71229	814402	.CONNECTION,HOSE	1
9	PAOZZ	81646	6806	.CLAMP PART OF KIT P/N 249680	1
10	XBOZZ	71229	239386-2	.TUBE,FILL,RESERVOIR	1
11	PAOZZ	71229	416-3301-013	.BUSHING,REDUCER, 1 IN. X 1/4 IN., BRASS	1
12	PAOZZ	71229	416-3301-010	.BUSHING,REDUCER, 1 IN. X 3/4 IN., BRASS	1
13	PAOZZ	71229	416-3301-011	.BUSHING,REDUCER, 1 IN. X 1/2 IN., BRASS	1
14	XDOZZ	71229	416-3305-006	.CROSS,1 IN.,BRASS	1
15	PAOZZ	71229	249669	.BOLT,U,SPECIAL	2
16	PAOZZ	71229	417-0037-055	.WASHER,PLAIN,1/4IN	8
17	PAOZZ	71229	417-0022-044	.NUT,HEX,1/4-20 UNC	8
18	PAOZZ	71229	416-3304-008	.COUPLING,REDUCER, 1 IN. X 3/4 IN., BRASS	1
19	PAOZZ	71229	251696-1	.COCK ASSY,DRAIN	1
	PAOOO	71229	249680	KIT,REPAIR	1
				CLAMP (4) 1-16	
				CLAMP (2) 1-24	
				CLAMP (1) 1-38	
				CLAMP (1) 5-9	
				DIAPHRAM (1) 2-19	
				FERRULE,TUBE (4) 2-12	
				NIPPLE,FLARING (1) 2-7	
				NIPPLE,FLARING (3) 2-10	
				NUT,TUBE (4) 2-11	
				TANK ASSY,RESERVOIR(1) 1-10	
				VALVE,CHECK (3) 2-5	
				WASHER,CHECK VALVE (7) 2-6	
				END OF FIGURE	

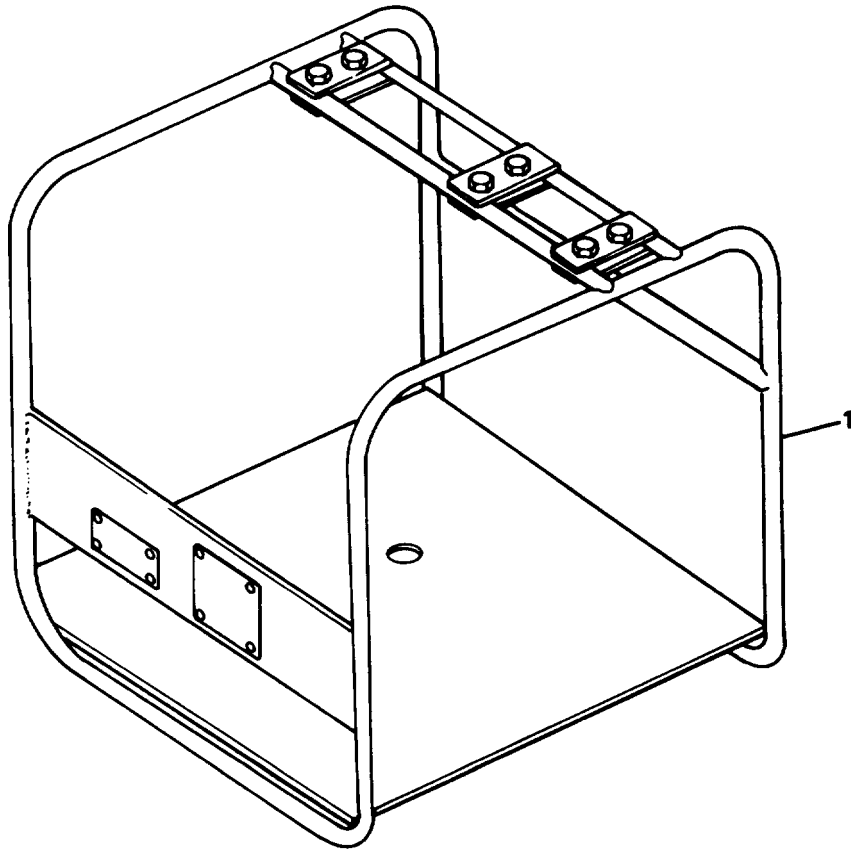

41043-215

Figure F-6. Frame

SECTION II

TM5-4610-233-13&P

(1) ITEM NO	(2) SMR CODE	(3) FSCM	(4) PART NUMBER	(5) DESCRIPTION AND USABLE ON CODE (UOC)	(6) QTY
				GROUP 05 FRAME, HYPOCHLORINTION UNIT	
				FIG. F-6 FRAME	
1	PAOOF	71229	245248-1	FRAME, HYPOCHLORINATION UNIT	1
				END OF FIGURE	

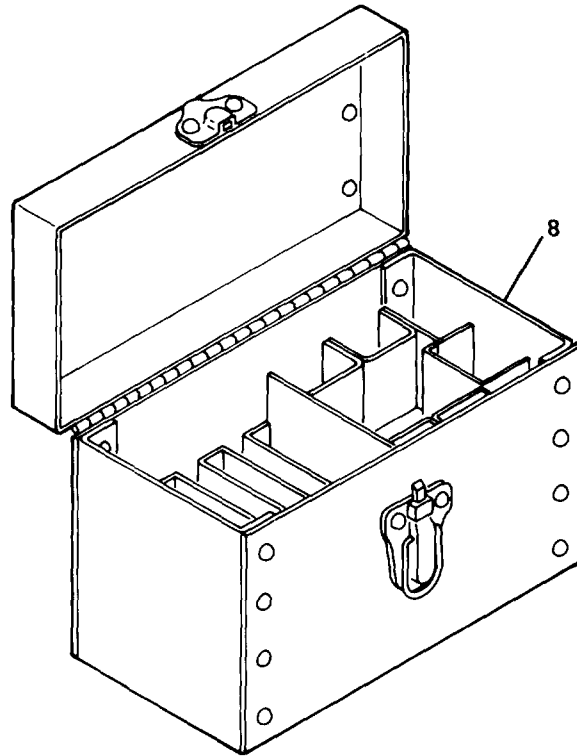
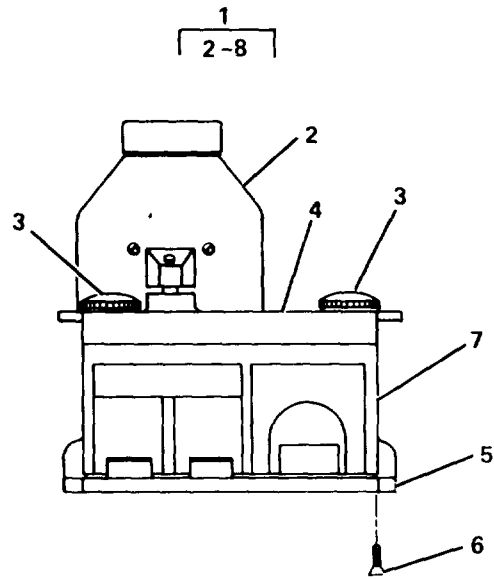

41043-216

Figure F-7. Chlorine Comparator Kit

(1) ITEM NO	(2) SMR CODE	(3) FSCM	(4) PART NUMBER	(5) DESCRIPTION AND USABLE ON CODE (UOC)	(6) QTY
GROUP 06 COMPARATOR, CHLORINE COLOR					
FIG. F-7 CHLORINE CAMPARATOR KIT					
1	PAOFF	97403	13200E7400	COMPARATOR,CHLORINE KIT	1
2	XDOZZ	97403	13200E7402	.EYEPiece,COMPARATOR	1
3	PAOZZ	97403	13200E7417	.THUMBSCREW	2
4	XDOZZ	97403	13200E7416	.COVER,FRONT	1
5	XDOZZ	97403	13200E7401	.COVER,BACK ASSY	1
6	PAOZZ	81348	FF-S-92	.SCREW,MACHINE, NO. 3-48 UNC-28 X .31L BRS.BLK.OXD	1
7	XDOZZ	97403	13200E7415	.HOUSING,COMPARATOR	1
8	XDOZZ	97403	13216E9016	.CASE,COLOR COMPARATOR	1

END OF FIGURE

SECTION II

TM5-4610-233-13&P

(1) ITEM NO	(2) SMR CODE	(3) FSCM	(4) PART NUMBER	(5) DESCRIPTION AND USABLE ON CODE (UOC)	(6) QTY
				GROUP 07 BULK	
1	PAOZZ	82094	4763	FOAM,GRAY, 1/2W X 1/4T, GRAY, POLYURETHANE FOAM	V
2	PAOZZ	71229	811805-2	TUBING,NYLOBRADE	V

END OF FIGURE

Section III. SPECIAL TOOLS LIST

Not Applicable

CROSS-REFERENCE INDEXES

NATIONAL STOCK NUMBER INDEX

STOCK NUMBER

FIG.

ITEM

STOCK NUMBER

FIG.

ITEM

NO DETAIL RECORDS QUALIFY FOR INDEX

SECTION IV

CROSS-REFERENCE INDEXES

PART NUMBER INDEX				
FSCM	PART NUMBER	STOCK NUMBER	FIG.	ITEM
71229	F-11		2	17
71229	F-921-1		2	11
81348	FF-S-92		7	6
71229	F920-BK		2	12
71229	G-1197-3		2	4
			2	15
71229	G-854		2	7
			2	10
71229	G-855		2	3
71229	0F726-V		2	19
97403	13200E7400		7	1
97403	13200E7401		7	5
97403	13200E7402		7	2
97403	13200E7415		7	7
97403	13200E7416		7	4
97403	13200E7417		7	3
97403	13216E9016		7	8
71229	180287-3		1	13
71229	181440-233		4	8
71229	182177-2		1	14
71229	191475-6		1	19
71229	239381		1	31
71229	239382		1	37
71229	239384		1	23
71229	239386-1		2	14
71229	239386-2		5	10
71229	239386-3		1	33
71229	239386-4		2	13
71229	239386-6		1	25
71229	239483		4	9
71229	239484		4	10
71229	239485		4	15
71229	239486		4	16
71229	239493		1	20
71229	245128		1	46
71229	245213		1	15
71229	245248-1		6	1
71229	245249		1	1
71229	249127		2	8
71229	249665		1	5
71229	249666		1	4
71229	249667		5	1
71229	249669		5	15
71229	249670		1	48
71229	249671		1	49
71229	249672		1	53
71229	249673		1	51
71229	249674-1		2	1
71229	249676		3	1
71229	249678		1	10
71229	249679		1	47

SECTION IV

CROSS-REFERENCE INDEXES

PART NUMBER INDEX				
FSCM	PART NUMBER	STOCK NUMBER	FIG.	ITEM
71229	249680		5	
71229	249682		4	1
71229	249683-3		1	9
71229	249690		1	29
71229	251024-1		1	39
71229	251024-2		1	17
71229	251024-3		1	18
71229	251293-2		1	16
			1	38
71229	251294		4	7
71229	251696-1		5	19
71229	260003		4	11
71229	260028		1	2
71229	260029		1	52
71229	416-3301-010		5	12
71229	416-3301-011		5	13
71229	416-3301-013		5	11
71229	416-3304-008		5	18
71229	416-3305-006		5	14
71229	416-3307-002		5	3
71229	416-3308-003		1	36
71229	416-3308-004		1	27
			1	41
71229	416-3308-005		1	22
71229	416-3309-012		5	6
71229	416-3309-013		5	4
71229	416-3309-034		1	30
71229	416-3309-046		1	21
71229	416-3310-002		1	28
71229	416-3311-002		5	5
71229	417-0022-044		5	17
71229	417-0037-055		5	16
71229	417-0075-718		1	50
71229	4170011063		4	12
71229	4170022025		1	8
71229	4170022026		1	45
71229	4170022027		4	14
71229	4170022029		4	6
71229	4170023042		1	12
71229	4170036025		4	13
71229	4170036027		4	5
71229	4170036322		1	7
71229	4170037024		1	44
71229	4170037056		1	43
71229	4170037059		4	4
71229	4170052126		1	42
71229	4170052176		4	2
71229	4170052492		4	3
71229	4170061724		2	16
71229	4170063663		1	11
71229	4170063678		1	3

SECTION IV

CROSS-REFERENCE INDEXES

PART NUMBER INDEX				
FSCM	PART NUMBER	STOCK NUMBER	FIG.	ITEM
71229	4170063741		1	6
71229	434-0102-004		5	2
71229	439-0101-002		5	7
71229	460179		2	20
82094	4763		BULK	1
81646	6806		1	24
			1	32
			5	9
71229	805285-2		2	18
71229	806365-4		2	9
71229	806515-3		2	5
71229	807305-2		2	2
71229	811805-2		BULK	2
71229	812699-1		2	6
71229	814398		1	35
71229	814399		1	26
71229	814400		1	40
71229	814402		1	34
			5	8

SECTION IV

CROSS-REFERENCE INDEXES

FIGURE AND ITEM NUMBER INDEX				
FIG.	ITEM	STOCK NUMBER	FSCM	PART NUMBER
BULK	1		82094	4763
BULK	2		71229	811805-2
1	1		71229	245249
1	2		71229	260028
1	3		71229	4170063678
1	4		71229	249666
1	5		71229	249665
1	6		71229	4170063741
1	7		71229	4170036322
1	8		71229	4170022025
1	9		71229	249683-3
1	10		71229	249678
1	11		71229	4170063663
1	12		71229	4170023042
1	13		71229	180287-3
1	14		71229	182177-2
1	15		71229	245213
1	16		71229	251293-2
1	17		71229	251024-2
1	18		71229	251024-3
1	19		71229	191475-6
1	20		71229	239493
1	21		71229	416-3309-046
1	22		71229	416-3308-005
1	23		71229	239384
1	24		81646	6806
1	25		71229	239386-6
1	26		71229	814399
1	27		71229	416-3308-004
1	28		71229	416-3310-002
1	29		71229	249690
1	30		71229	416-3309-034
1	31		71229	239381
1	32		81646	6806
1	33		71229	239386-3
1	34		71229	814402
1	35		71229	814398
1	36		71229	416-3308-003
1	37		71229	239382
1	38		71229	251293-2
1	39		71229	251024-1
1	40		71229	814400
1	41		71229	416-3308-004
1	42		71229	4170052126
1	43		71229	4170037056
1	44		71229	4170037024
1	45		71229	4170022026
1	46		71229	245128
1	47		71229	249679
1	48		71229	249670
1	49		71229	249671

SECTION IV

CROSS-REFERENCE INDEXES

FIGURE AND ITEM NUMBER INDEX				
FIG.	ITEM	STOCK NUMBER	FSCM	PART NUMBER
1	50		71229	417-0075-718
1	51		71229	249673
1	52		71229	260029
1	53		71229	249672
2	1		71229	249674-1
2	2		71229	807305-2
2	3		71229	G-855
2	4		71229	G-1197-3
2	5		71229	806515-3
2	6		71229	812699-1
2	7		71229	G-854
2	8		71229	249127
2	9		71229	806365-4
2	10		71229	G-854
2	11		71229	F-921-1
2	12		71229	F920-BK
2	13		71229	239386-4
2	14		71229	239386-1
2	15		71229	G-1197-3
2	16		71229	4170061724
2	17		71229	F-11
2	18		71229	805285-2
2	19		71229	OF726-V
2	20		71229	460179
3	1		71229	249676
4	1		71229	249682
4	2		71229	4170052176
4	3		71229	4170052492
4	4		71229	4170037059
4	5		71229	4170036027
4	6		71229	4170022029
4	7		71229	251294
4	8		71229	181440-233
4	9		71229	239483
4	10		71229	239484
4	11		71229	260003
4	12		71229	4170011063
4	13		71229	4170036025
4	14		71229	4170022027
4	15		71229	239485
4	16		71229	239486
5			71229	249680
5	1		71229	249667
5	2		71229	434-0102-004
5	3		71229	416-3307-002
5	4		71229	416-3309-013
5	5		71229	416-3311-002
5	6		71229	416-3309-012
5	7		71229	439-0101-002
5	8		71229	814402
5	9		81646	6806

SECTION IV

CROSS-REFERENCE INDEXES

FIGURE AND ITEM NUMBER INDEX				
FIG.	ITEM	STOCK NUMBER	FSCM	PART NUMBER
5	10		71229	239386-2
5	11		71229	416-3301-013
5	12		71229	416-3301-010
5	13		71229	416-3301-011
5	14		71229	416-3305-006
5	15		71229	249669
5	16		71229	417-0037-055
5	17		71229	417-0022-044
5	18		71229	416-3304-008
5	19		71229	251696-1
6	1		71229	245248-1
7	1		97403	13200E7400
7	2		97403	13200E7402
7	3		97403	13200E7417
7	4		97403	13200E7416
7	5		97403	13200E7401
7	6		81348	FF-S-92
7	7		97403	13200E7415
7	8		97403	13216E9016

SUBJECT INDEX

Subject	Paragraph, Figure, Table Number
A	
Adjustments, Initial.....	2-5
Administrative Storage Requirements	4-35
Antisiphon Valve, Replace	4-22
C	
Check Valve	
Repair.....	4-24
Replace	4-23
Chlorine Color Comparator, Replace	3-3
Common Tools and Equipment	4-1
Controls and Indicators	2-1, T2-1
Cover, Repair.....	5-3
D	
Destruction of Army Materiel to Prevent Enemy Use	1-5
Drain Hose Assembly	
Repair.....	4-18
Replace	4-17
E	
Equipment Characteristics, Capabilities, and Features	1-9
Equipment Data	1-11
Explanation of Columns (Unit PMCS Table)	4-6
F	
Flow Controller, Replace.....	4-26
Foot Valve, Replace.....	4-21
Frame	
Repair.....	5-2
Replace	4-33
H	
Hypochlorination Unit Instruction Plate Location	F2-3
Hypochlorination Unit Schematic Diagram.....	F1-3

Subject	Paragraph, Figure, Table Number
I	
Initial Adjustments	2-5
Inlet and Outlet Hoses, Replace	4-11
Inlet Hose Assembly	
Repair	4-14
Replace	4-13
Instruction Plate Location, Hypochlorination Unit	F2-3
L	
Location and Description of Major Components	1-10, F1-2
M	
Maintenance Forms, Records, and Reports	1-2
Manifold Assembly	
Repair	4-30
Replace	4-29
O	
Operating Instructions on Decals and Instruction Plates	2-8
Operating Procedure	2-6
Operation in Unusual Weather	2-9
Operator Preventive Maintenance Checks and Services	2-3, T2-2
Operator Troubleshooting	3-2, T3-1
Outlet Hose Assembly	
Repair	4-16
Replace	4-15
P	
PMCS Procedures	
Operator	2-3, T2-2
Unit	T4-1
Preparation for Movement	2-7
Preparation for Storage or Shipment	1-6
Preparation for Use	2-4, F2-2
Preservation, Packaging, Marking, and Shipping	
Requirements	4-34
Pressure Gage, Replace	4-31
Preventive Maintenance Checks and Services (Interval)	
Schedule, Unit	T4-1
Preventive Maintenance Checks and Services, Operator	T2-2

Subject	Paragraph, Figure, Table Number
Q	
Quality Assurance/Quality Control (QA/QC)	1-7
R	
Repair	
Check Valve	4-24
Cover	5-3
Drain Hose Assembly	4-18
Frame	5-2
Inlet Hose Assembly	4-14
Manifold Assembly	4-30
Outlet Hose Assembly	4-16
Solution Feed Pump	4-20
4-Inch Manifold Assembly	4-28
Repair Parts	4-3
Replace	
Antisiphon Valve	4-22
Check Valve	4-23
Chlorine Color Comparator	3-3
Drain Hose Assembly	4-17
Flow Controller	4-26
Foot Valve	4-21
Frame	4-33
Inlet and Outlet Hoses	4-11
Inlet Hose Assembly	4-13
Manifold Assembly	4-29
Outlet Hose Assembly	4-15
Pressure Gage	4-31
Reservoir Tank Assembly	4-10
Shutoff Cock	4-12
Solution Feed Pump	4-19
Solution Feed Pump Diaphragm	4-25
Tool Box	4-9
1/4-Inch Globe Valve	4-32
4-Inch Manifold Assembly	4-27
Reporting Equipment Improvement Recommendations (EIR)	1-3
Reservoir Tank Assembly, Replace	4-10
S	
Safety, Care, and Handling	1-8
Schematic Description	1-12
Schematic Diagram, Hypochlorination Unit	F1-3
Service Upon Receipt of Materiel	4-4
Shutoff Cock, Replace	4-12

Subject	Paragraph, Figure, Table Number
Solution Feed Pump	
Repair	4-20
Replace	4-19
Solution Feed Pump Diaphragm, Replace	4-25
Special Tools, TMDE, and Support Equipment	4-2
T	
Tool Box, Replace	4-9
Troubleshooting Table	
Operator	3-2, T3-1
Unit	4-8, T4-2
U	
Unit Preventive Maintenance Checks and Services	
(Interval) Schedule	T4-1
Unit Troubleshooting	4-8, T4-2
W	
Warranty Information	1-4
Water Purification Hypochlorination Unit, Model 1955-3	F1-1
1/4-inch Globe Valve, Replace	4-32
4-Inch Manifold Assembly	
Repair	4-28
Replace	4-27

By Order of the Secretary of the Army:

CARL E. VUONO
General, United States Army
Chief of Staff

Official:

WILLIAM J. MEEHAN, II
Brigadier General, United States Army
The Adjutant General

DISTRIBUTION:

To be distributed in accordance with DA Form 12-25A, Operator, Unit and Direct Support Maintenance requirements for Water Purification, Hypochlorination Unit, Frame Mounted, 100 GPM (A-506111)

These are the instructions for sending an electronic 2028

The following format must be used if submitting an electronic 2028. The subject line must be exactly the same and all fields must be included; however only the following fields are mandatory: 1,3,4,5,6,7,8, 9, 10, 13, 15, 16, 17, and 27.

From: "Whomever" <whomever@avma27.army.mil>

To: mpmt%avma28@st-louis-emh7.army.mil

Subject: DA Form 2028

1. **From:** Joe Smith
2. **Unit:** home
3. **Address:** 4300 Park
4. **City:** Hometown
5. **St:** MO
6. **Zip:** 77777
7. **Date Sent:** 19-OCT-93
8. **Pub no:** 55-2840-229-23
9. **Pub Title:** TM
10. **Publication Date:** 04-JUL-85
11. **Change Number:** 7
12. **Submitter Rank:** MSG
13. **Submitter FName:** Joe
14. **Submitter MName:** T
15. **Submitter LName:** Smith
16. **Submitter Phone:** 123-123-1234
17. **Problem:** 1
18. **Page:** 2
19. **Paragraph:** 3
20. **Line:** 4
21. **NSN:** 5
22. **Reference:** 6
23. **Figure:** 7
24. **Table:** 8
25. **Item:** 9
26. **Total:** 123
27. **Text:**

This is the text for the problem below line 27.

RECOMMENDED CHANGES TO EQUIPMENT TECHNICAL PUBLICATIONS

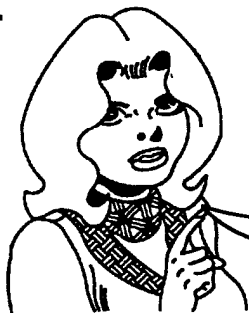

SOMETHING WRONG WITH THIS PUBLICATION?

THEN . . . JOT DOWN THE DOPE ABOUT IT ON THIS FORM, CAREFULLY TEAR IT OUT, FOLD IT AND DROP IT IN THE MAIL!

FROM: (PRINT YOUR UNIT'S COMPLETE ADDRESS)

PFC John DOE
CO 4 3rd Engineer Bn
Ft. Leonardwood, MO 63108

DATE SENT

22 August 1992

PUBLICATION NUMBER

TM 1-1520-250-10

PUBLICATION DATE

15 June 1992

PUBLICATION TITLE

Operator's manual MH60K Helicopter

BE EXACT PIN-POINT WHERE IT IS

IN THIS SPACE, TELL WHAT IS WRONG AND WHAT SHOULD BE DONE ABOUT IT:

PAGE NO	PARA-GRAPH	FIGURE NO	TABLE NO
6	2-1 a		
B1		4-3	

In line 6 of paragraph 2-1a the manual states the engine has 6 cylinders. The engine on my set only has 4 cylinders. Change the manual to show 4 cylinders.

Callout 16 on figure 4-3 is pointed at a bolt. In key to figure 4-3, item 16 is called a shim. Please correct one or the other

PRINTED NAME, GRADE OR TITLE, AND TELEPHONE NUMBER

JOHN DOE, PFC (268) 317-7111

SIGN HERE

JOHN DOE *John Doe*

DA FORM 2028-2
1 JUL 79

PREVIOUS EDITIONS ARE OBSOLETE.
DRSTS-M verprint2, 1 Nov 80

P.S. - IF YOUR OUTFIT WANTS TO KNOW ABOUT YOUR RECOMMENDATION, MAKE A CARBON COPY OF THIS AND GIVE TO YOUR HEADQUARTERS.

FILL IN YOUR
UNITS ADDRESS



FOLD BACK

DEPARTMENT OF THE ARMY

OFFICIAL BUSINESS

COMMANDER
U.S. ARMY AVIATION AND TROOP COMMAND
ATTN: AMSAT-I-MP
4300 GOODFELLOW BOULEVARD
ST. LOUIS, MO 63120-1798

TEAR ALONG PERFORATED LINE

RECOMMENDED CHANGES TO EQUIPMENT TECHNICAL PUBLICATIONS

SOMETHING WRONG WITH THIS PUBLICATION?



THEN . . . JOT DOWN THE DOPE ABOUT IT ON THIS FORM, CAREFULLY TEAR IT OUT, FOLD IT AND DROP IT IN THE MAIL!

FROM: (PRINT YOUR UNIT'S COMPLETE ADDRESS)

DATE SENT

PUBLICATION NUMBER

TM 5-4610-233-13&P

PUBLICATION DATE

12 April 1990

PUBLICATION TITLE

Water Purification Hypochlorination Unit

BE EXACT PIN-POINT WHERE IT IS

IN THIS SPACE, TELL WHAT IS WRONG AND WHAT SHOULD BE DONE ABOUT IT:

PAGE NO	PARA-GRAPH	FIGURE NO	TABLE NO

PRINTED NAME, GRADE OR TITLE, AND TELEPHONE NUMBER

SIGN HERE

FILL IN YOUR
UNITS ADDRESS



FOLD BACK

DEPARTMENT OF THE ARMY

OFFICIAL BUSINESS

COMMANDER
U.S. ARMY AVIATION AND TROOP COMMAND
ATTN: AMSAT-I-MP
4300 GOODFELLOW BOULEVARD
ST. LOUIS, MO 63120-1798

TEAR ALONG PERFORATED LINE

RECOMMENDED CHANGES TO EQUIPMENT TECHNICAL PUBLICATIONS



THEN . . . JOT DOWN THE DOPE ABOUT IT ON THIS FORM, CAREFULLY TEAR IT OUT, FOLD IT AND DROP IT IN THE MAIL!

SOMETHING WRONG WITH THIS PUBLICATION?

FROM: (PRINT YOUR UNIT'S COMPLETE ADDRESS)

DATE SENT

PUBLICATION NUMBER
TM 5-4610-233-13&P

PUBLICATION DATE
12 April 1990

PUBLICATION TITLE
Water Purification Hypochlorination Unit

BE EXACT PIN-POINT WHERE IT IS

IN THIS SPACE, TELL WHAT IS WRONG AND WHAT SHOULD BE DONE ABOUT IT:

PAGE NO	PARA-GRAPH	FIGURE NO	TABLE NO

PRINTED NAME, GRADE OR TITLE, AND TELEPHONE NUMBER

SIGN HERE

FILL IN YOUR
UNITS ADDRESS

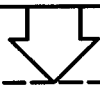

FOLD BACK

DEPARTMENT OF THE ARMY

OFFICIAL BUSINESS

COMMANDER
U.S. ARMY AVIATION AND TROOP COMMAND
ATTN: AMSAT-I-MP
4300 GOODFELLOW BOULEVARD
ST. LOUIS, MO 63120-1798

TEAR ALONG PERFORATED LINE

RECOMMENDED CHANGES TO EQUIPMENT TECHNICAL PUBLICATIONS



THEN . . . JOT DOWN THE DOPE ABOUT IT ON THIS FORM, CAREFULLY TEAR IT OUT, FOLD IT AND DROP IT IN THE MAIL!

SOMETHING WRONG WITH THIS PUBLICATION?

FROM: (PRINT YOUR UNIT'S COMPLETE ADDRESS)

DATE SENT

PUBLICATION NUMBER TM 5-4610-233-13&P	PUBLICATION DATE 12 April 1990	PUBLICATION TITLE Water Purification Hypochlorination Unit
---	--	--

BE EXACT PIN-POINT WHERE IT IS				IN THIS SPACE, TELL WHAT IS WRONG AND WHAT SHOULD BE DONE ABOUT IT:
PAGE NO	PARA-GRAPH	FIGURE NO	TABLE NO	

PRINTED NAME, GRADE OR TITLE, AND TELEPHONE NUMBER	SIGN HERE
---	------------------

FILL IN YOUR
UNITS ADDRESS



FOLD BACK

DEPARTMENT OF THE ARMY

OFFICIAL BUSINESS

COMMANDER
U.S. ARMY AVIATION AND TROOP COMMAND
ATTN: AMSAT-I-MP
4300 GOODFELLOW BOULEVARD
ST. LOUIS, MO 63120-1798

TEAR ALONG PERFORATED LINE

The Metric System and Equivalents

Linear Measure

1 centimeter = 10 millimeters = .39 inch
 1 decimeter = 10 centimeters = 3.94 inches
 1 meter = 10 decimeters = 39.37 inches
 1 dekameter = 10 meters = 32.8 feet
 1 hectometer = 10 dekameters = 328.08 feet
 1 kilometer = 10 hectometers = 3,280.8 feet

Weights

1 centigram = 10 milligrams = .15 grain
 1 decigram = 10 centigrams = 1.54 grains
 1 gram = 10 decigram = .035 ounce
 1 dekagram = 10 grams = .35 ounce
 1 hectogram = 10 dekagrams = 3.52 ounces
 1 kilogram = 10 hectograms = 2.2 pounds
 1 quintal = 100 kilograms = 220.46 pounds
 1 metric ton = 10 quintals = 1.1 short tons

Liquid Measure

1 centiliter = 10 milliliters = .34 fl. ounce
 1 deciliter = 10 centiliters = 3.38 fl. ounces
 1 liter = 10 deciliters = 33.81 fl. ounces
 1 dekaliter = 10 liters = 2.64 gallons
 1 hectoliter = 10 dekaliters = 26.42 gallons
 1 kiloliter = 10 hectoliters = 264.18 gallons

Square Measure

1 sq. centimeter = 100 sq. millimeters = .155 sq. inch
 1 sq. decimeter = 100 sq. centimeters = 15.5 sq. inches
 1 sq. meter (centare) = 100 sq. decimeters = 10.76 sq. feet
 1 sq. dekameter (are) = 100 sq. meters = 1,076.4 sq. feet
 1 sq. hectometer (hectare) = 100 sq. dekameters = 2.47 acres
 1 sq. kilometer = 100 sq. hectometers = .386 sq. mile

Cubic Measure

1 cu. centimeter = 1000 cu. millimeters = .06 cu. inch
 1 cu. decimeter = 1000 cu. centimeters = 61.02 cu. inches
 1 cu. meter = 1000 cu. decimeters = 35.31 cu. feet

Approximate Conversion Factors

To change	To	Multiply by	To change	To	Multiply by
inches	centimeters	2.540	ounce-inches	newton-meters	.007062
feet	meters	.305	centimeters	inches	.394
yards	meters	.914	meters	feet	3.280
miles	kilometers	1.609	meters	yards	1.094
square inches	square centimeters	6.451	kilometers	miles	.621
square feet	square meters	.093	square centimeters	square inches	.155
square yards	square meters	.836	square meters	square feet	10.764
square miles	square kilometers	2.590	square meters	square yards	1.196
acres	square hectometers	.405	square kilometers	square miles	.386
cubic feet	cubic meters	.028	square hectometers	acres	2.471
cubic yards	cubic meters	.765	cubic meters	cubic feet	35.315
fluid ounces	milliliters	29.573	cubic meters	cubic yards	1.308
pints	liters	.473	milliliters	fluid ounces	.034
quarts	liters	.946	liters	pints	2.113
gallons	liters	3.785	liters	quarts	1.057
ounces	grams	28.349	liters	gallons	.264
pounds	kilograms	.454	grams	ounces	.035
short tons	metric tons	.907	kilograms	pounds	2.205
pound-feet	newton-meters	1.356	metric tons	short tons	1.102
pound-inches	newton-meters	.11296			

Temperature (Exact)

°F	Fahrenheit temperature	5/9 (after subtracting 32)	Celsius temperature	°C
----	------------------------	----------------------------	---------------------	----

